

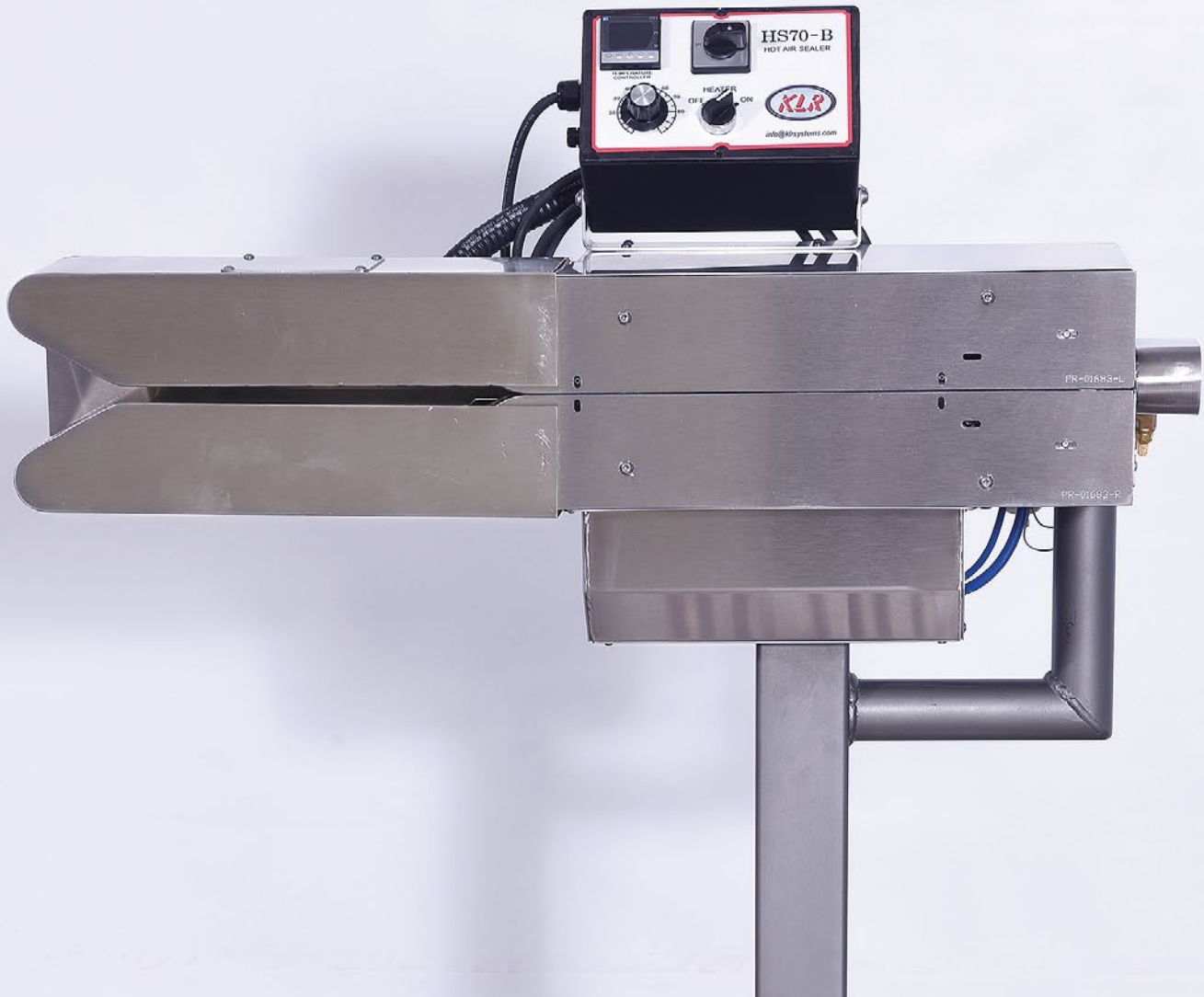

# KLR HS 70B



944, Des Hérons  
Saint-Pie, (Qc) Canada  
J0H 1W0

T : (450) 388-0404  
T : 1-800-918-8777

info@klrsystems.com  
[www.klrsystems.com](http://www.klrsystems.com)



DEPUIS/SINCE  
1977



Contents

- IDENTIFICATION ..... 2
  - The product brand and type designation ..... 2
  - Version of product/edition ..... 2
  - Serial number location:..... 2
- Name and address of the manufacturer..... 3
- Declaration of conformity with standards of products ..... 3
- Range of applications intended use and general functions..... 3
- Dimensions and weight (for transport) ..... 3
- INSTALLATION ..... 3
  - Power for electricity and air data ..... 3
  - Location of the instructions ..... 4
- OPERATION ..... 4
  - Control panel ..... 4
  - On/off air pressure:..... 4
  - Temperature controller ..... 4
  - Belt potentiometer ..... 5
- SAFETY PRECAUTIONS..... 5
  - Personal protective ..... 5
  - Security labels. .... 5
  - Safety components ..... 6
- MAINTENANCE AND CLEANING ..... 6
  - Preventive maintenance schedule..... 6
  - Blade replacement..... 7
  - Disassemble the top part ..... 9
  - Silicon wheel replacement (same procedure for heating block) ..... 10
  - Explanations ..... 13
  - Replace driving belts ..... 14
  - Replace chain ..... 15
- MAINTENANCE AND REPARATIONS BY TECHNICIANS FROM KLR SYSTEMS INC. .... 15
  - Address and contact information for service technicians ..... 15
- DECOMMISSIONING OF THE PRODUCT ..... 15

SPARE PARTS LIST.....	16
EXPLODED VIEWS KLR.HS70B .....	18
VACUUM AND BLOWER #1 OPTION .....	22
VACUUM .....	23
CAPPING.....	24
BLOWER #1 SYSTEM.....	25
BLOWER #2 OPTION.....	28
PANEL CONTROL.....	29
SUPPORT.....	29
PNEUMATIC.....	30
SEALER UPPER MECHANIC.....	32
SEALER LOWER MECHANIC.....	33
MOTOR.....	34
UPPER SEALER.....	35
LOWER SEALER.....	39
ELECTRICAL PLANS.....	43

## IDENTIFICATION

The product brand and type designation

KLR.HS70B

Bag sealer

Version of product/edition

Take note that every picture and every document were not especially for a left or a right version of this product. These instructions remain appropriate for the opposite. The left version is the mirror of the right.

**How to recognize left or right:**

For example, the following picture shows that the sealer is a left-hand version. You need to imagine yourself on the conveyor facing in the direction of the flow, and the hand that happen to be the side of the sealer give the answer.

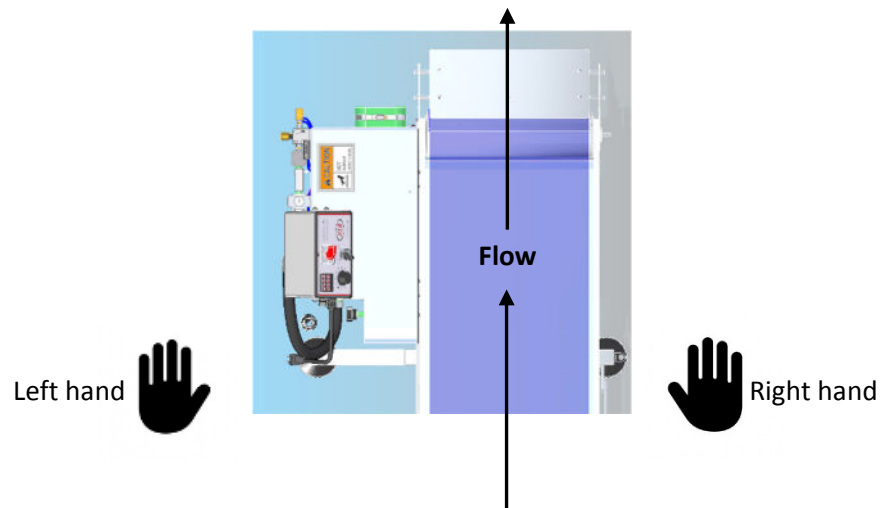

**Serial number location:**

Located in the back, on top of the pneumatic modules.





## Name and address of the manufacturer

KLR SYSTEMS INC.

944 Heron Street,

Saint-Pie, Quebec, Canada

JOH 1W0

## Declaration of conformity with standards of products

Standard: CE

## Range of applications intended use and general functions

This device has been designed to remove the air mostly, seal plastic bag and cut the excess of the bag. It is also compact, lightweight so it can be rapidly replaced for maintenance without stopping the production. The automatic sealer can be installed directly on the conveyor or on a mobile unit.

## Dimensions and weight (for transport)

## INSTALLATION

The following picture shows how the sealer is mainly installed directly on a conveyor.

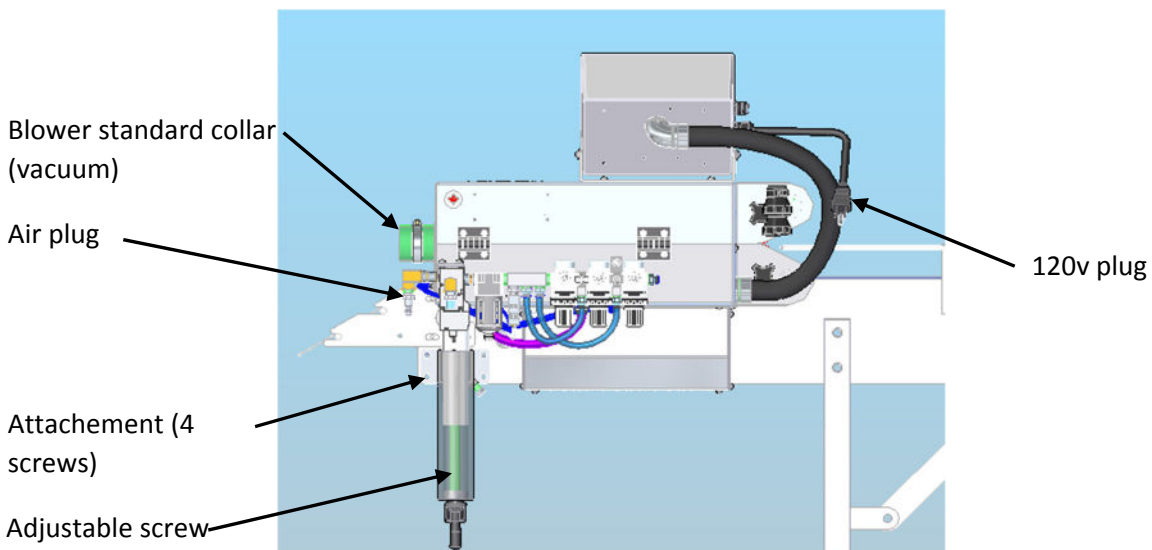

## Power for electricity and air data

Electric: 120v, 60 hertz, 1 phase

Pneumatic: 80 psi

## Location of the instructions

Instructions location: during the shipment of this device, his instructions are in the packaging itself. Also, this document is available online : [www.klrsystems.com](http://www.klrsystems.com)

## OPERATION

### Control panel

here you can control the temperature, the speed of the belts and turn on/off the sealer.



\*Temperatures are in Celsius (c)

### On/off air pressure:

The heater won't turn on if the air pressure switch is off because of a pressure valve. This prevents the heater burning itself because there is no circulating air in the system. Simply turn on the air pressure first, and then the heater.

### Temperature controller



By turning on the heater, the temperature will gradually rise up to reach the temperature set point.

The temperature required for good result highly depend on the thickness of the bag and the speed of the conveyor. Basically, higher the speed of the conveyor, less time the bag will be engaged into the sealer. Raise the temperature when the bag takes less time to be sealed. Higher the thickness of the material, higher the temperature needs to be as well.

As the temperature rise to get to the set point. It is normal to see higher temperature few seconds and then go under few degrees. It will correct itself and be more precise gradually.

## Potentiometer Belt

The belt must go the same speed as the conveyor. One advice is to make either the conveyor and the sealer working. Take a bag and put it on the conveyor the way to engage into the sealer. Simulate the weight of the product by hand. You will see if the bag goes faster or slower than adjust the speed with the wheel on the control panel.

## SAFETY PRECAUTIONS

### Personal protective

**Air blower:** please, wear safety glasses when using an air blower for cleaning.

**Habit:** For more safety, Long hair should be tied. Use sleeveless clothes avoid shirt bottoms that could be driving into the moving part. Clothing can easily be driven into the sealer by the belt action.

**Sharp blades:** This machine is equipped with a ceramic blade inside. When blade handling, we highly recommend wearing cut resistant gloves due to extremely sharp blade in the design, there a feature that rotates the blade inside when the top part of the sealer is disassembled. This help safety but does not remove all danger. Consider removing the blade for more safety when needed (**see "blade replacement" further in the maintenance part to know how to remove it**)



### Security labels.

Safety labels are there for your safety, Keep them clean and legible. Do not remove them even if it is blocking line of sight. If you must replace a piece with a safety label on it, please order a label to replace it as well.



Hot surface: This machine uses high temperature in the normal conditions. One or multiple surfaces might be hot. Theses surfaces may be hot for several minutes after the sealer has been turned off.

We do recommend waiting 15 minutes after the shut off before doing any maintenance, cleaning and other operations.



Sharp blades inside: This machine uses a ceramic knife. Careful especially on maintenance operations because the knife is more likely to be exposed. Consider removing the blade for more safety when needed. Please use cut-resistant gloves.

### Safety Components

This machine is designed to be as safe as possible. Danger areas have been enclosed with cases or doors for better protections.

Safety panel or safety doors: As a safety component does not try to remove or unscrew them unless it is necessary for a maintenance operation. Do keep in mind to use pad lock during this procedure and to reassemble every single piece as it was when finished.

## MAINTENANCE AND CLEANING

### Preventive maintenance schedule

Here is a quick way to take care of your machine by a preventive maintenance schedule:

PREVENTIVE MAINTENANCE SCHEDULE			
Location	Procedure	Time interval	Remarks
Belts	Verify the wear of each belt	3 months	None
Chain	Verify the wear of each chain	3 months	None
Cleaning	Air blow	daily	For more safety, wait 15 minutes to prevent burn
Blade	Check a sealed bag, check the quality of the seal. Check if it is a sharp cut. If not, change or rotate the blade	when needed, highly depends on the production.	Work with cut-resistant glove
Silicon wheels	Replace if it does not have a uniform seal and has bubbled inside.	2-3 months	None

## Blade replacement

Before changing the blade, keep in mind that the blade has technically four sides to be used before it wore down. It is made or ceramic, so it is worn resistant;

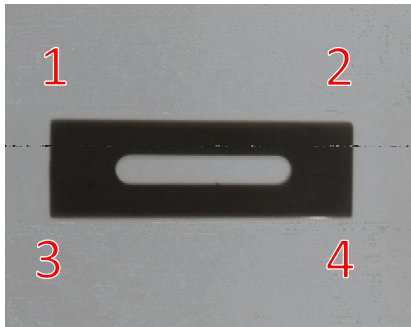

Here are the steps to remove/replace/rotate the blades:

- Turn OFF the sealer and wait at least 15 minutes;
- Unplug the power cord;
- Unscrew both hand screws from the vacuum chamber (vacuum chamber is an option on purchase), then remove the vacuum chamber;



- Open the top plate;

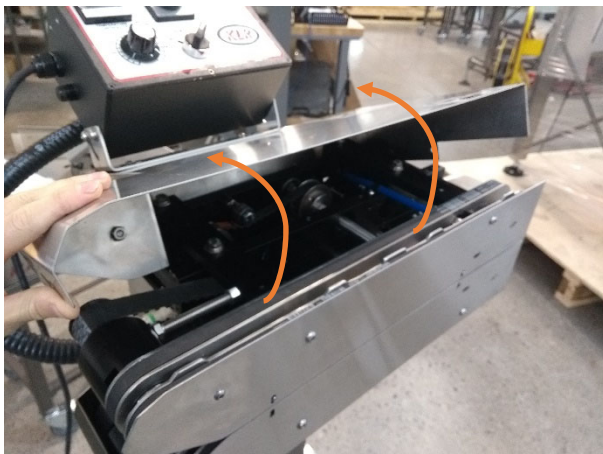



- Unscrew two socket cap screws that hold both top and bottom assembly together;

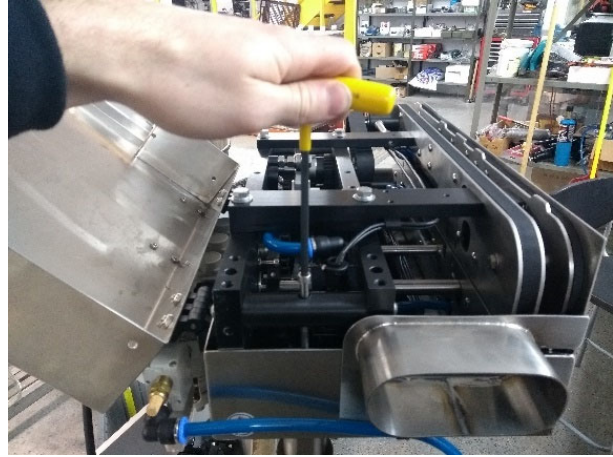
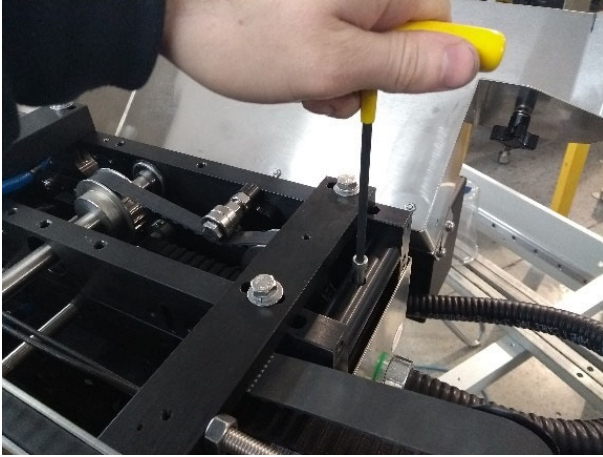

- Remove the top assembly;

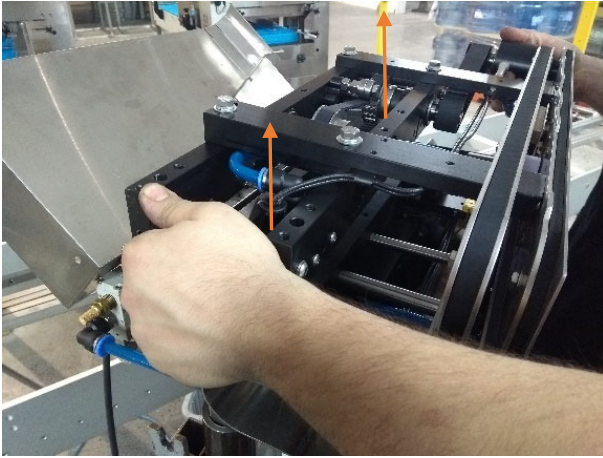

- Careful, this is a safety purpose mechanism. When the top assembly is installed, the blade is raised;

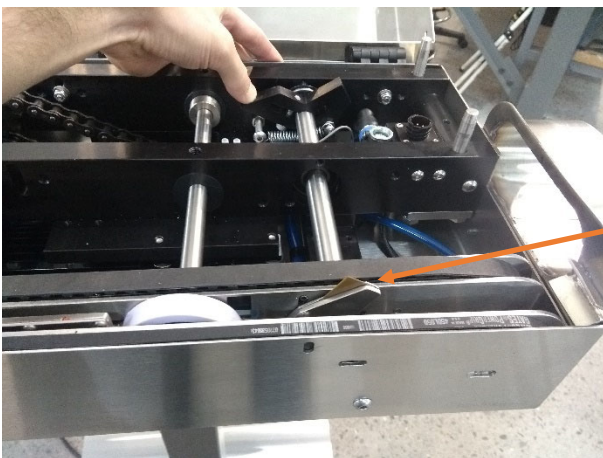

Blade

- Unscrew 3 screws from the blade holder;

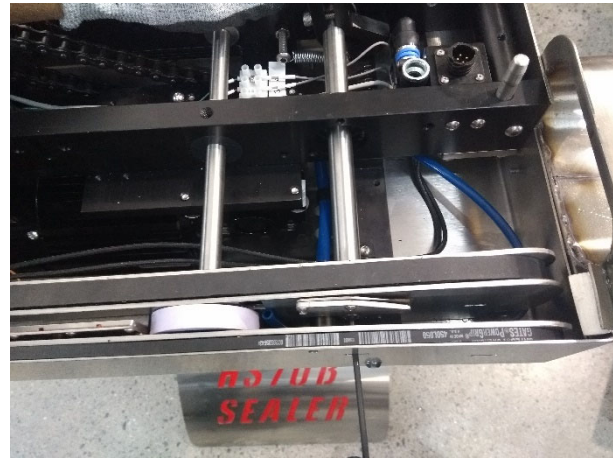
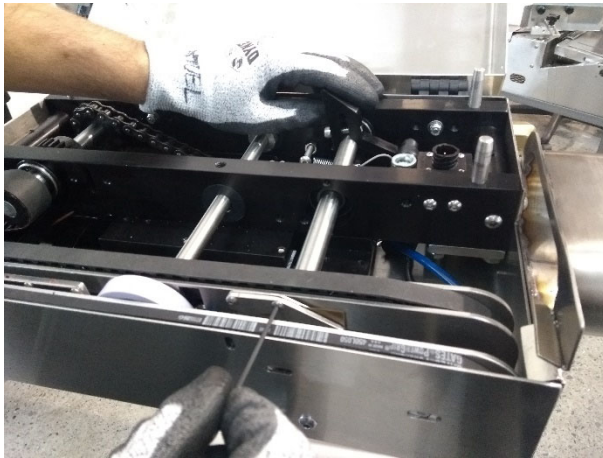

- Remove/replace/rotate the blade;

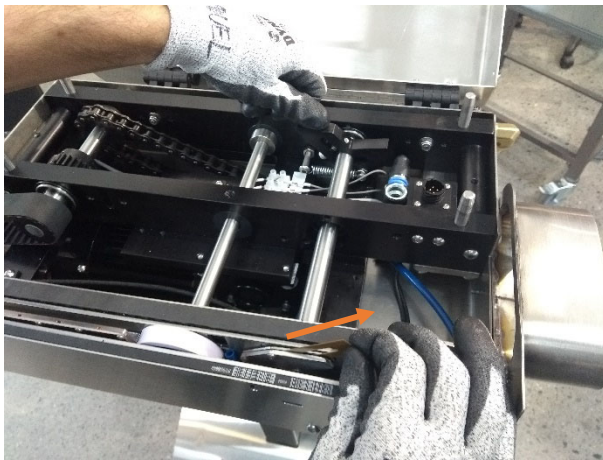

### Disassemble the top part

- Remove the vacuum chamber;
- Open the top of the sealer;
- Unscrew two (2) main screws with a 3/16 Allen key;

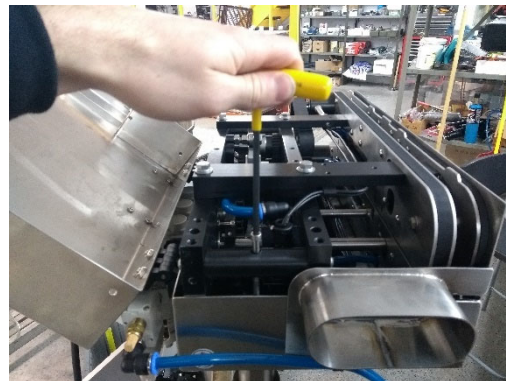
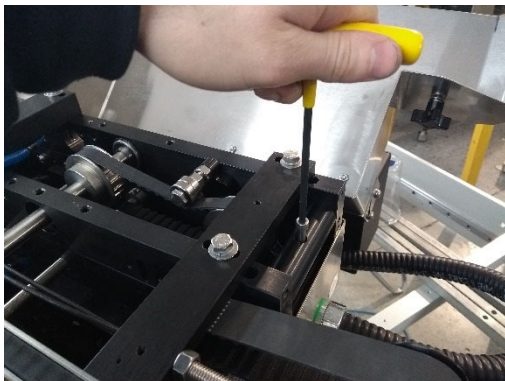

- Remove top part;

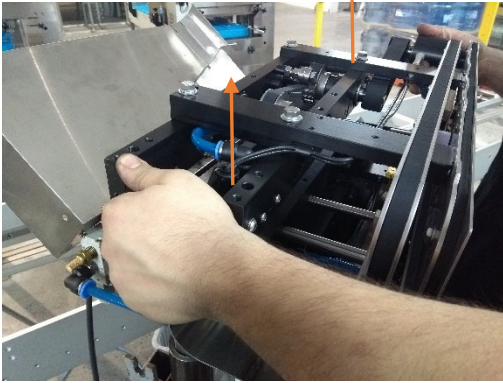

### Silicon wheel replacement (same procedure for heating blocks)

In the following steps, only the top part is shown to avoid repeating. Bottom part is the same except there are NO springs.

- Unscrew both hand screws from the vacuum chamber (vacuum chamber is an option on purchase), then remove the vacuum chamber. **See page 6 for pictures;**
- Remove those three screws (one 10-32 and two ¼-20), then remove the plate;

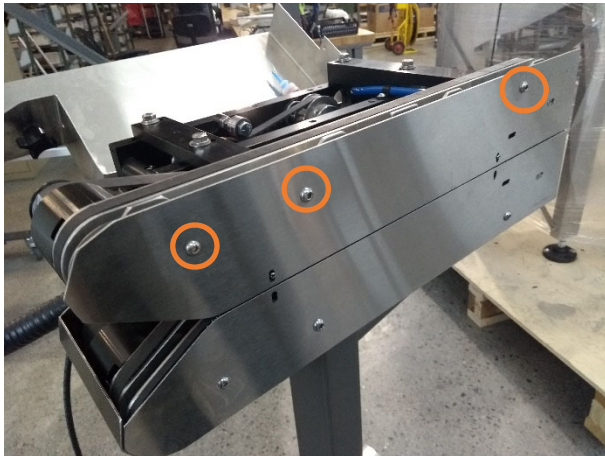



- Remove both (2) springs;

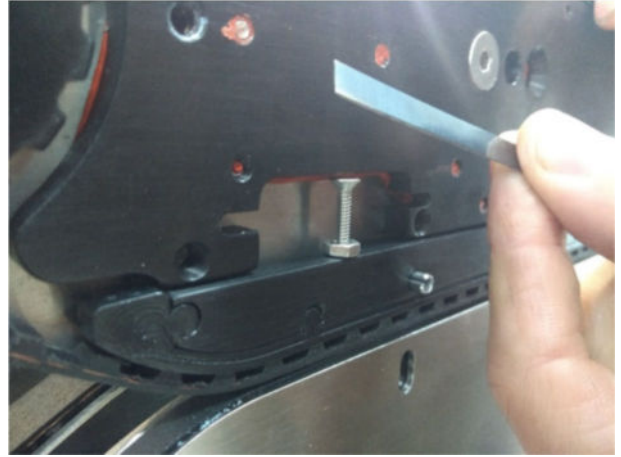
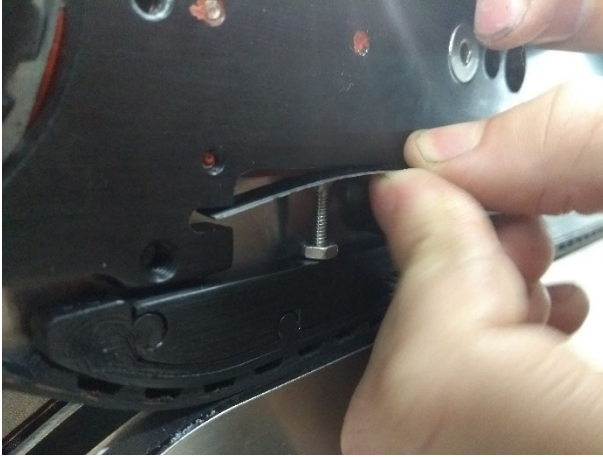

- Remove the belt skate;



- Remove the belt and the plastic wheel;

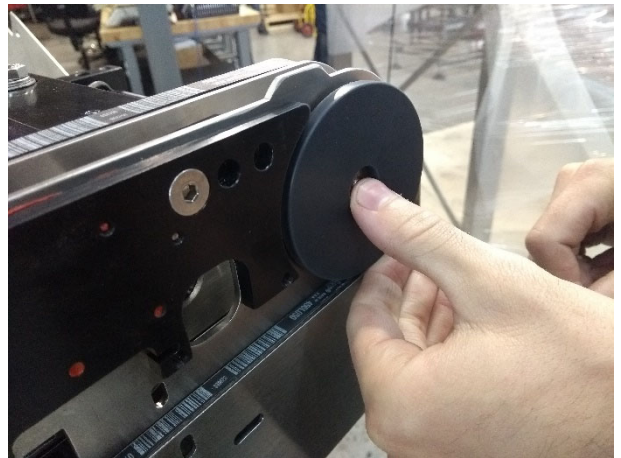

- Unscrew two set screws on the driving wheel and remove it, **careful** when you reassemble it, there is a flat on the shaft to receive one of the set screws;

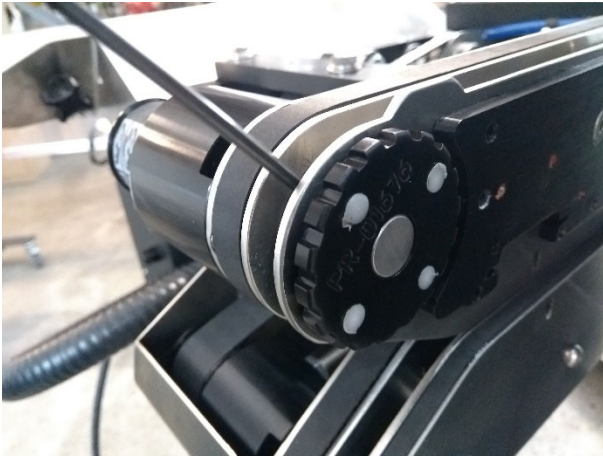

- Unscrew both screws of the guide and unplug each air hoses (**The blue lip of the hoses fitting needs to be pressed to be able to remove the hose**);

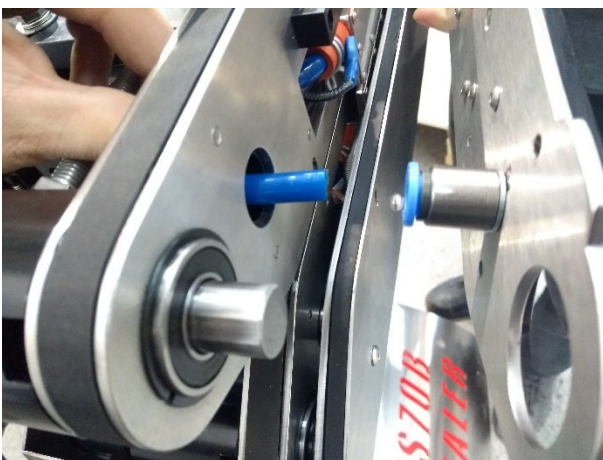
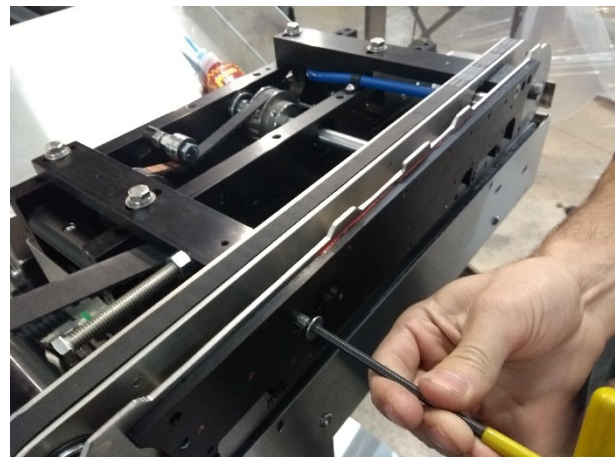
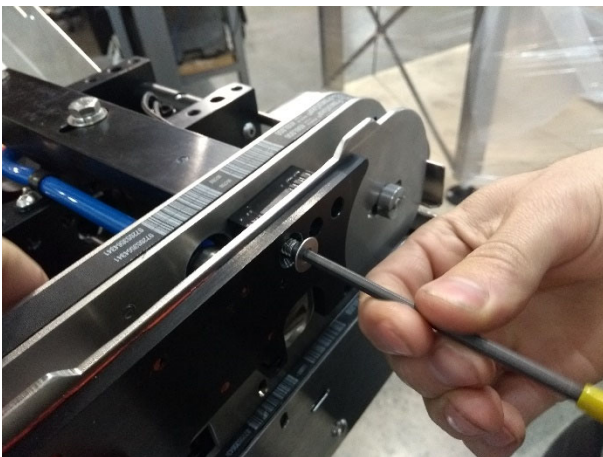



- You have access to the silicon wheel, replace the wheel (1 screws);

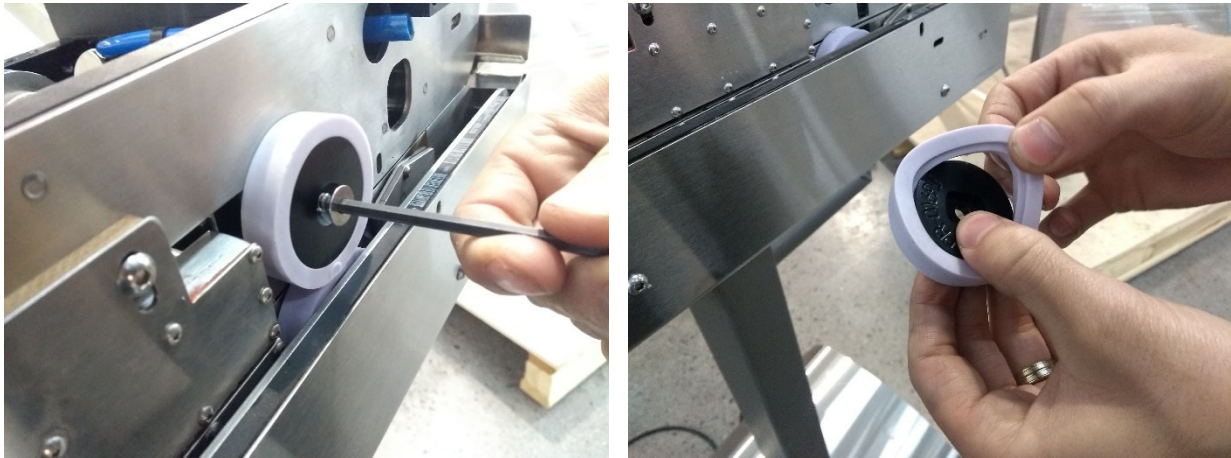

- Follow the exact same steps but reversed to reassemble.

## Explanations

### Pneumatic explanation:

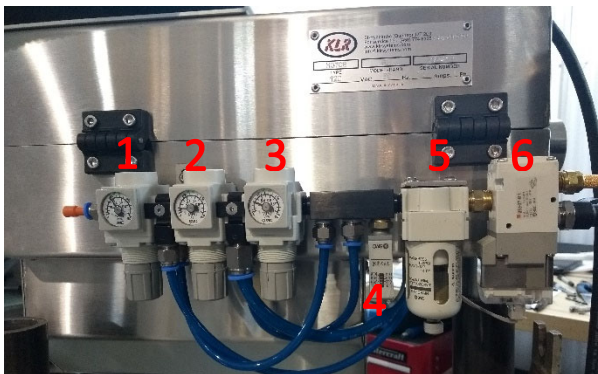

1. Venturi (optional)
2. Cooling blowers
3. Heating blower
4. Pressure sensor
5. Water separator
6. Shut off valve

### Things to know:

- Top and bottom parts are mirroring each other except: the cutting blade is at the bottom; silicon wheel is only driven at the top (bottom one is free) and there are springs for the belt at the bottom as well.
- This screw is NOT an adjustable screw or a tensioner. It has been fixed once in the assembly, and it is there to hold that cylinder part.

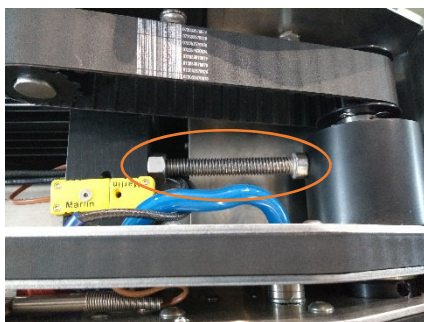

- Heating blocks must be adjusted this way:

Heating block



Adjusting slots

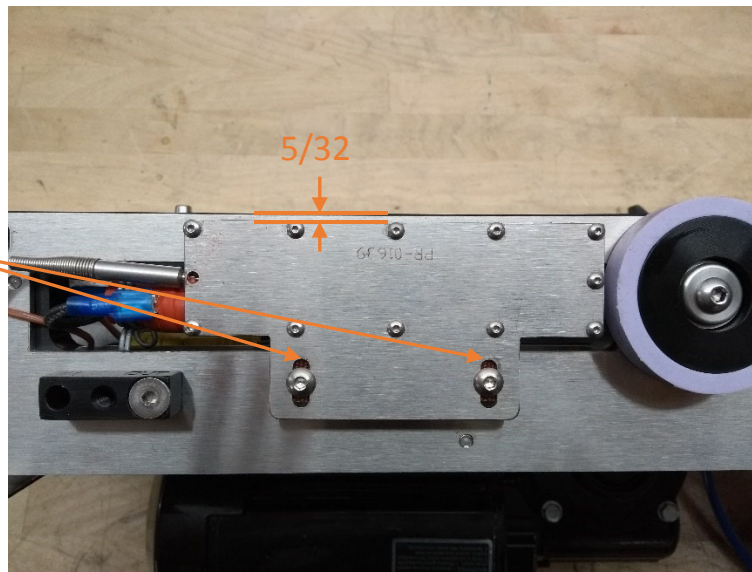

### Replace driving belts

Four (4) bolts are there to hold the tension of the belt of the bottom part (same thing for the top). See second picture.

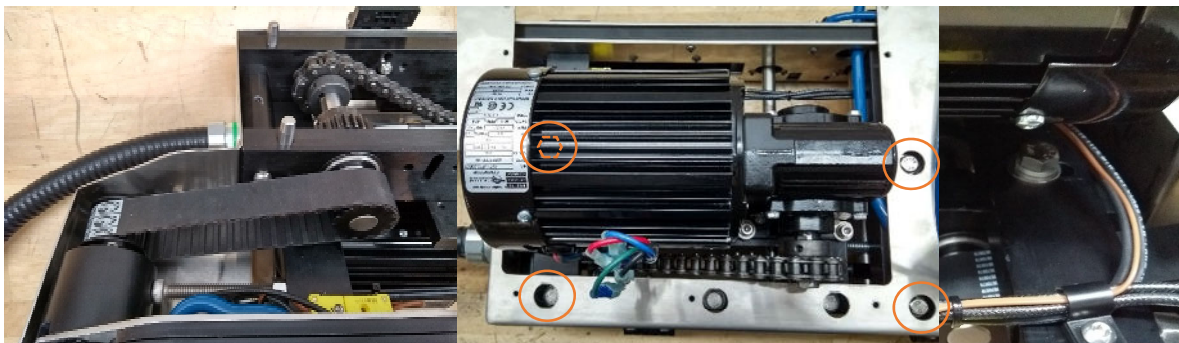

## Replace chain

Three (3) bolts are there to hold the tension of the chain

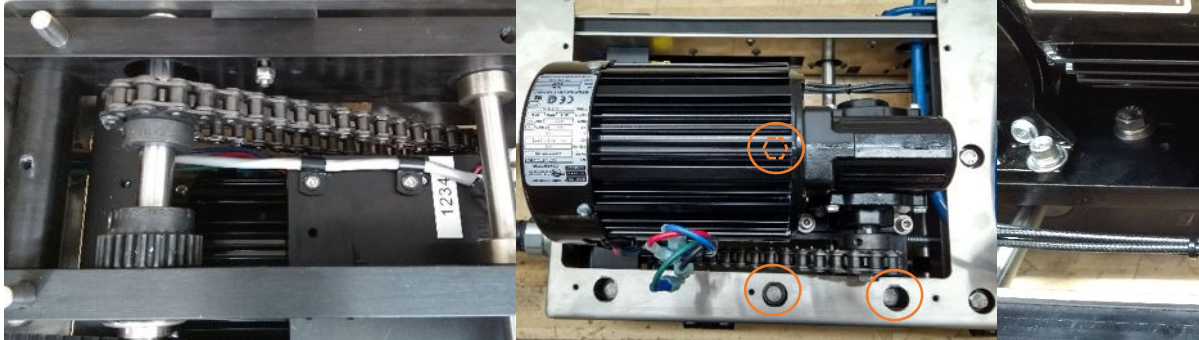

MAINTENANCE AND REPARATIONS BY TECHNICIANS FROM KLR SYSTEMS INC.

## Address and contact information for service technicians

For technical support or any other questions:

KLR SYSTEMS INC.

944 Heron Street,

Saint-Pie, Quebec, Canada

J0H 1W0

(450)-388-0404

[Info@klrsystems.com](mailto:Info@klrsystems.com)

[www.klrsystems.com](http://www.klrsystems.com)

## DECOMMISSIONING OF THE PRODUCT

It is advisable to plan a tour of KLR to reinstall the equipment after a prolonged deactivation or a move.

Destruction, recycling, disposal

## SPARE PARTS LIST

Here is the list of parts per machine we do recommend keeping in your facility.

There are options available for your machine. If you need to order a piece, make sure to look in the right list. If you need assistance, see contact information right above.

Numbers	Part numbers	Quantity	Descriptions
1	PR-01667	2	TIMING BELT
2	PR-01846	2	TIMING BELT
3	PM-00607	1	TIMING BELT
4	PM-00056	2	TIMING BELT
5	P02-00133	4	BEARING
6	P02-00095	2	BEARING
7	PM-02133	1	BEARING
8	PR-01792	1	GEAR
9	PE-00367	1	THERMOCOUPLE CONNECTOR FEMALE
10	PR-01631	6	SILICONE WHEEL
11	PE-00368	1	THERMOCOUPLE CONNECTOR MALE
12	PR-01644	4	BELT WEAR STRIP 1/4"
13	PR-01674	2	SPRING STEEL
14	PR-01674-E	2	SPRING STEEL
15	PE-00370	2	HEATER
16	PE-00372	1	THERMOCOUPLE
17	PP-00693	1	PRESSURE REGULATOR
18	PP-00692	1	PRESSURE INTERRUPTOR
19	PM-02001	1	ROUND BLADE (HS70B-ROUND-CUT UPDATE)
20	PM-02001-A	1	BLADE CERAMIC (OBSOLETE)

REFERENCE: BC 2260 (2024-08-29)



# Exploded views

SINCE  
1977

---



SYSTEMES **KLR** SYSTEMS Inc

# KLR.HS70B

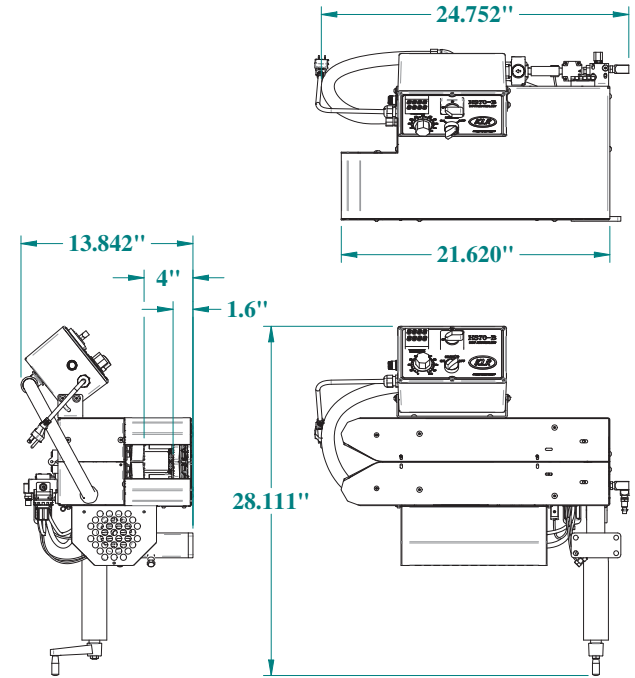



# OPTION OTHER POSSIBLE CONFIGURATION

KLR.HS70B-VANTURY

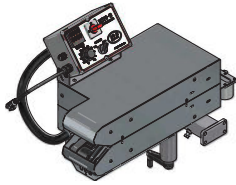

KLR.HS70B-VAC1B  
(VACUUM AND 1 BLOWER)

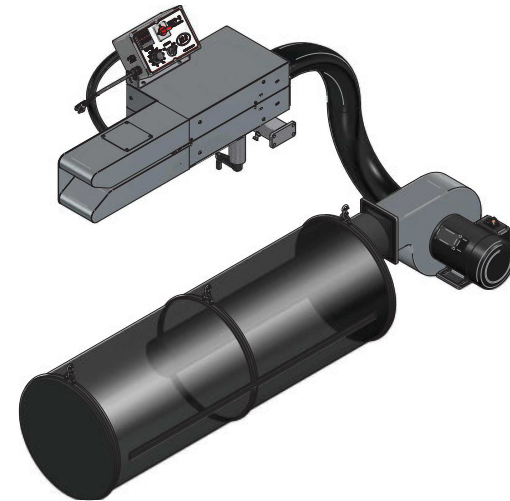

KLR.HS70B-1B  
(1 BLOWER)



KLR.HS70B-VAC2B  
(1 VACUUM AND 2 BLOWER)



# OPTION

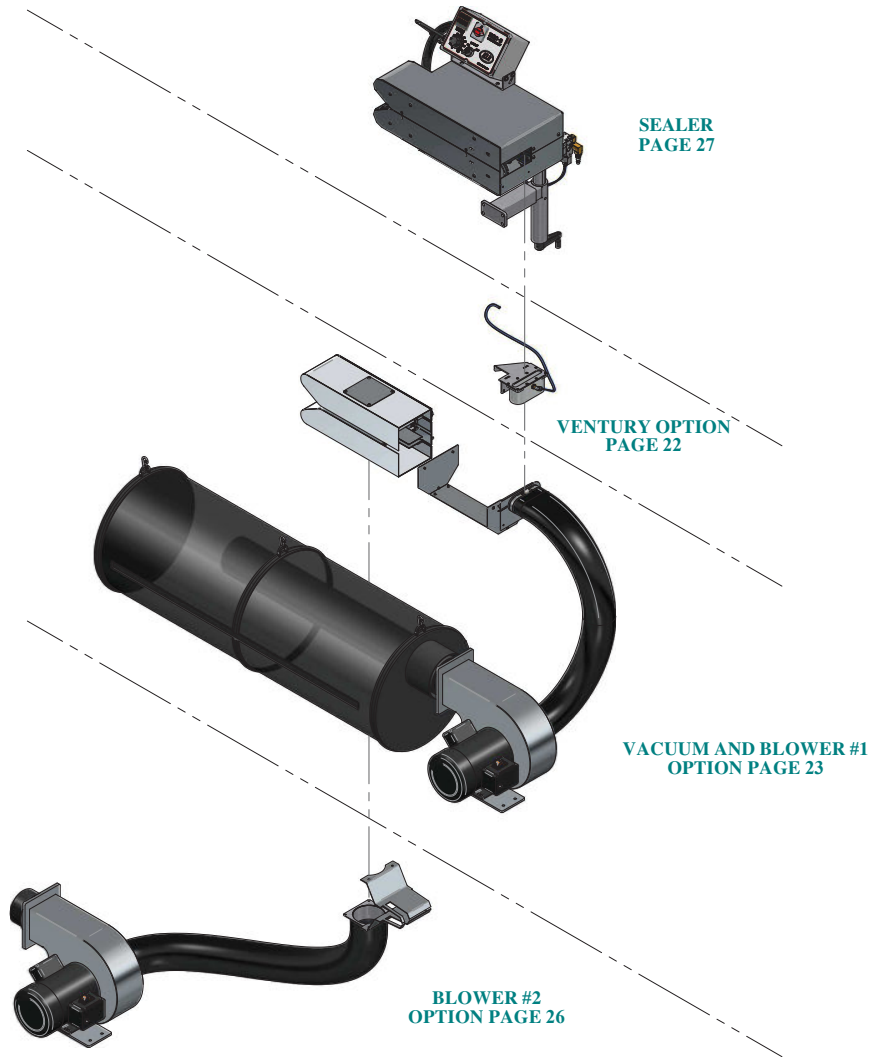

## VENTURY OPTION

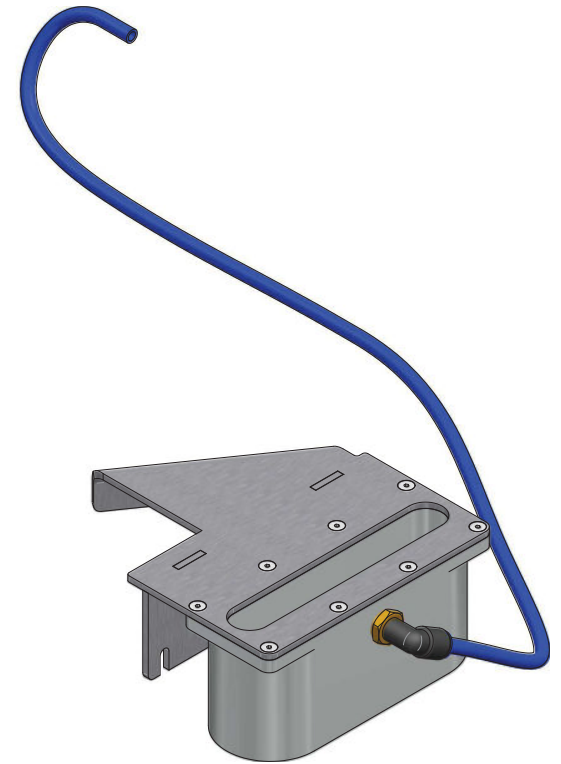
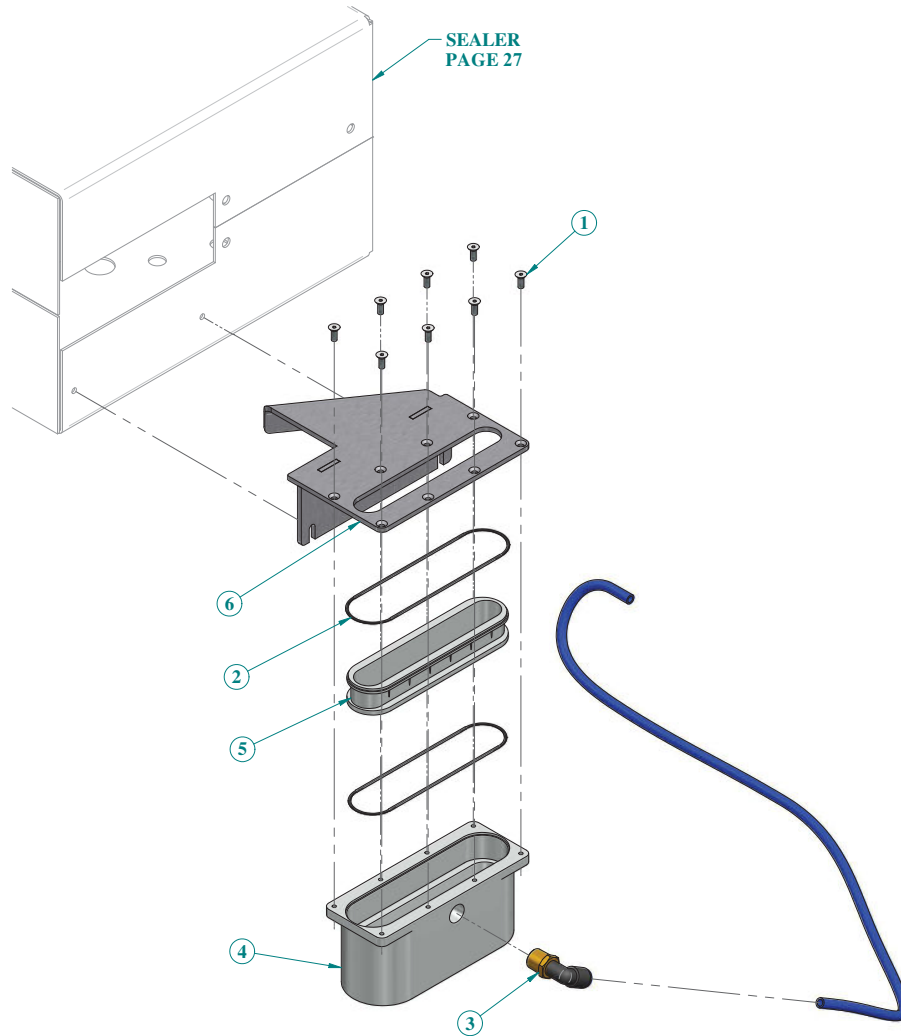

KLR.HS70B			
No.	# Document	Qte	Title
1	F12-138C06S	8	FLAT HEAD 6-32 X 3/8" STAINLESS
2	PM-02985	2	O-RING
3	PP-00161	1	90 DEGREES ELBOW 1/4 TUB X 1/4 NPT
4	PR-01699-3	1	VENTURY COLLECTOR
5	PR-01699-4	1	VENTURY INSERT
6	PR-01699-L	1	TOP PLATE ASSEMBLY

# VACUUM AND BLOWER #1 OPTION

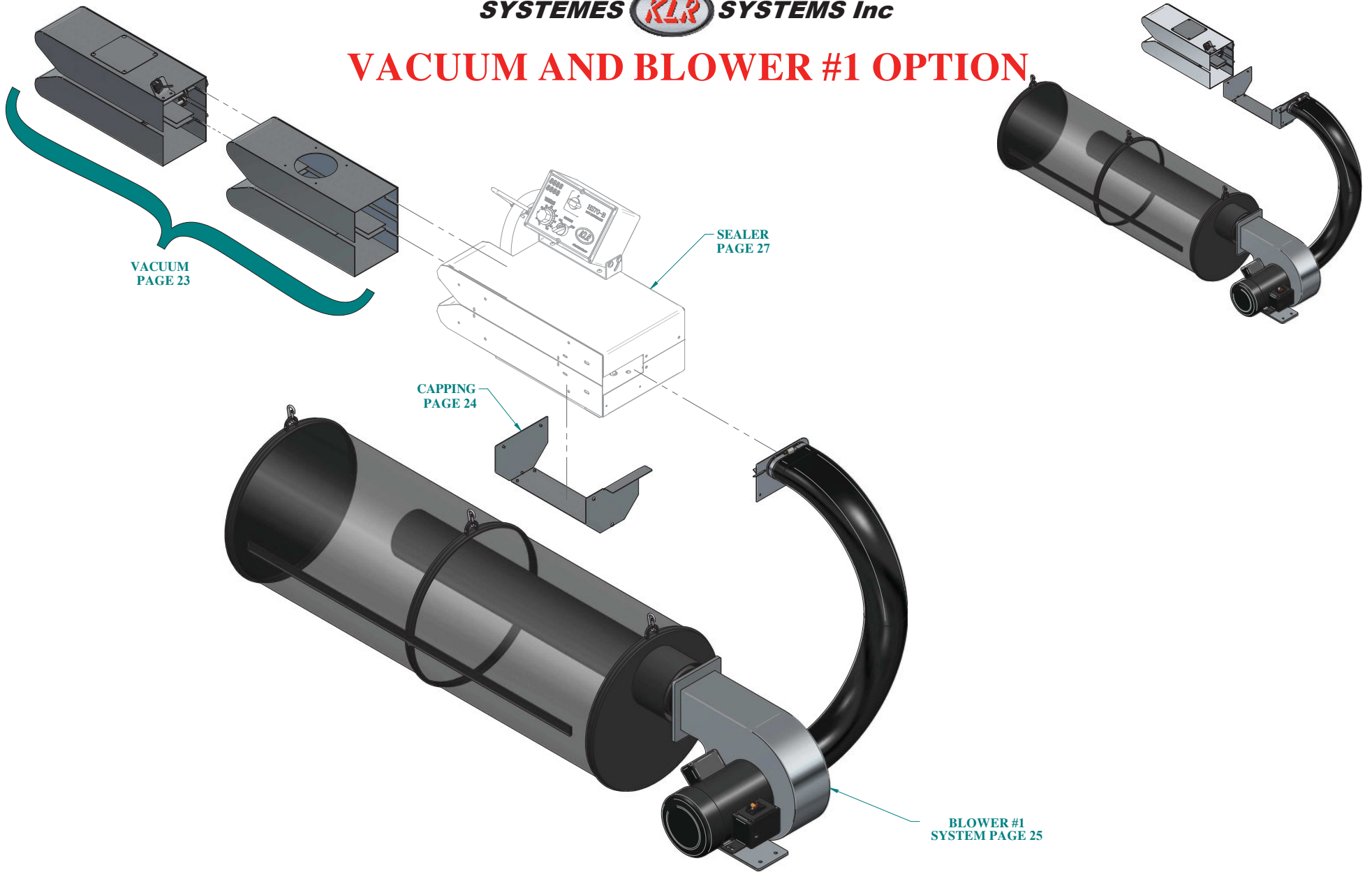

**SYSTEMES *KLR* SYSTEMS Inc**  
**VACUUM**

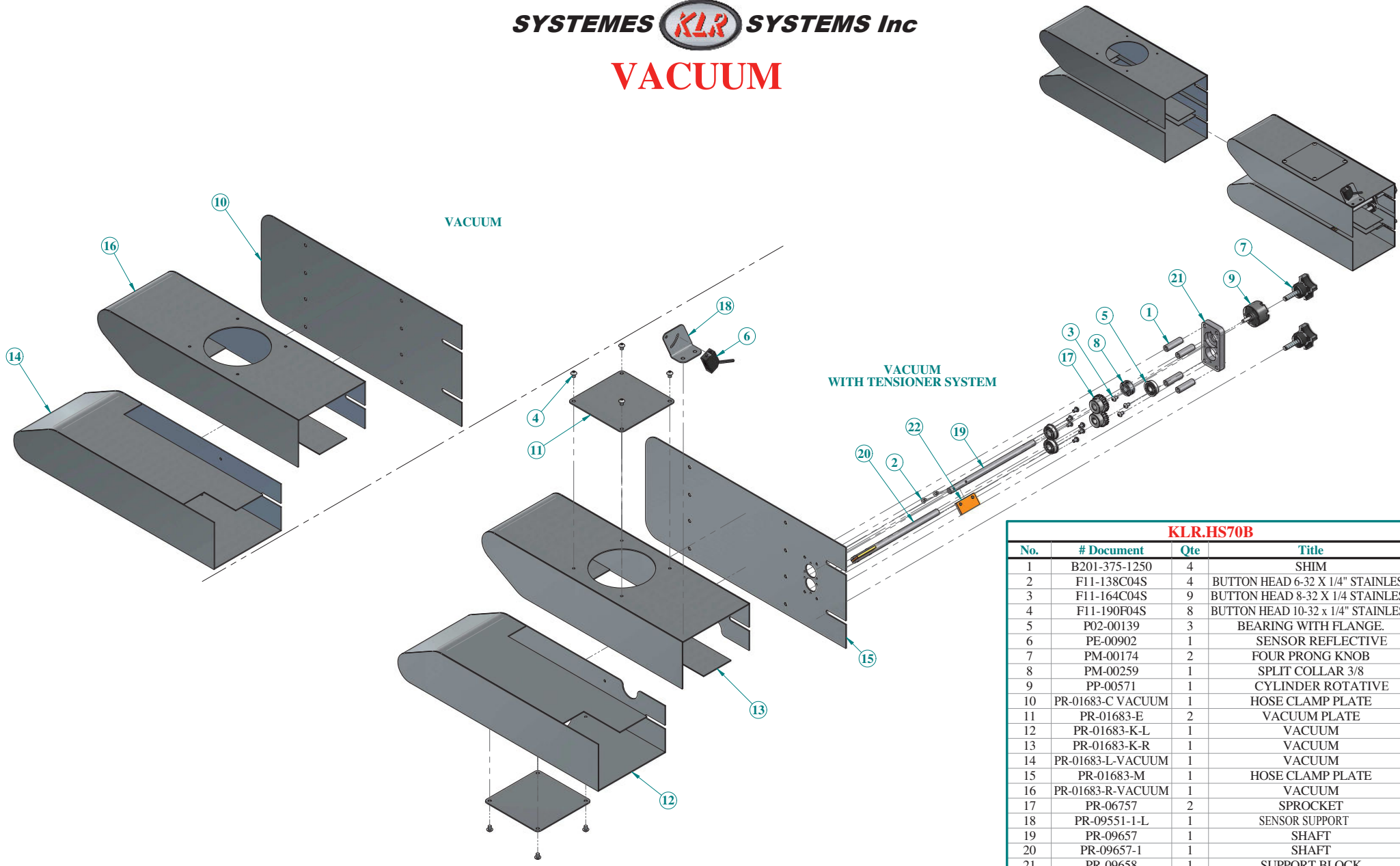

KLR.HS70B			
No.	# Document	Qty	Title
1	B201-375-1250	4	SHIM
2	F11-138C04S	4	BUTTON HEAD 6-32 X 1/4" STAINLESS
3	F11-164C04S	9	BUTTON HEAD 8-32 X 1/4" STAINLESS
4	F11-190F04S	8	BUTTON HEAD 10-32 x 1/4" STAINLESS
5	P02-00139	3	BEARING WITH FLANGE.
6	PE-00902	1	SENSOR REFLECTIVE
7	PM-00174	2	FOUR PRONG KNOB
8	PM-00259	1	SPLIT COLLAR 3/8
9	PP-00571	1	CYLINDER ROTATIVE
10	PR-01683-C VACUUM	1	HOSE CLAMP PLATE
11	PR-01683-E	2	VACUUM PLATE
12	PR-01683-K-L	1	VACUUM
13	PR-01683-K-R	1	VACUUM
14	PR-01683-L-VACUUM	1	VACUUM
15	PR-01683-M	1	HOSE CLAMP PLATE
16	PR-01683-R-VACUUM	1	VACUUM
17	PR-06757	2	SPROCKET
18	PR-09551-1-L	1	SENSOR SUPPORT
19	PR-09657	1	SHAFT
20	PR-09657-1	1	SHAFT
21	PR-09658	1	SUPPORT BLOCK
22	PR-09659	2	SILICONE FINGER FOR WRINKLE ELIMINATOR

**SYSTEMES  SYSTEMS Inc**  
**CAPPING**

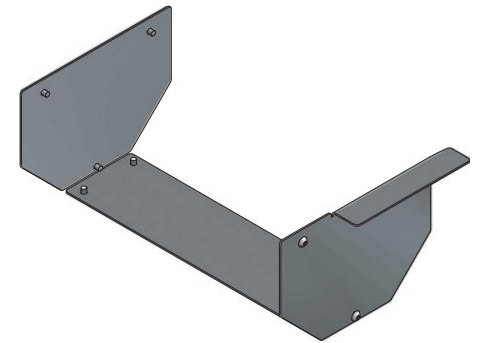
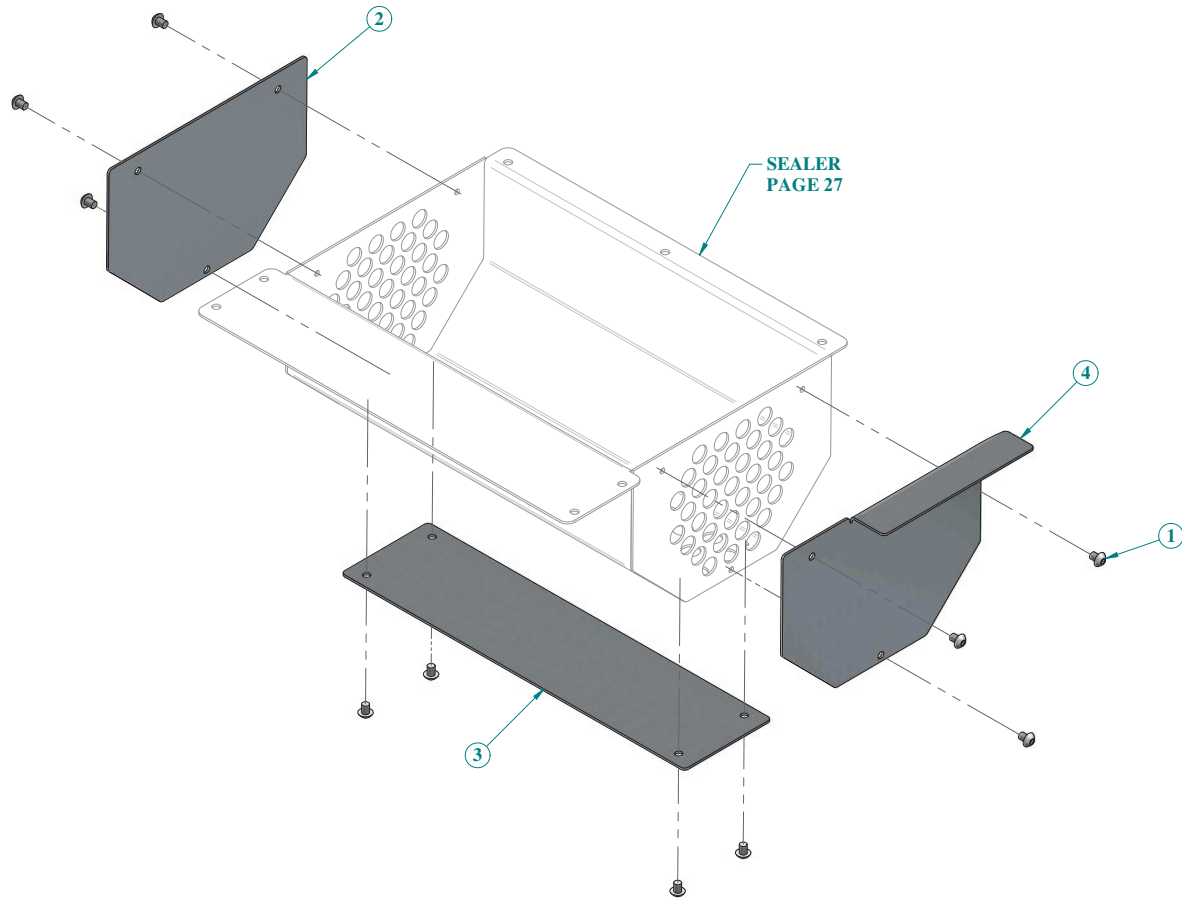

<b>KLR.HS70B</b>			
No.	# Document	Qte	Title
1	F11-190F04S	10	BUTTON HEAD 10-32 x 1/4" STAINLESS
2	PR-01663-D	1	VACUUM PLATE
3	PR-01663-E	1	VACUUM PLATE
4	PR-01663-F-L	1	VACUUM PLATE

# BLOWER #1 SYSTEM

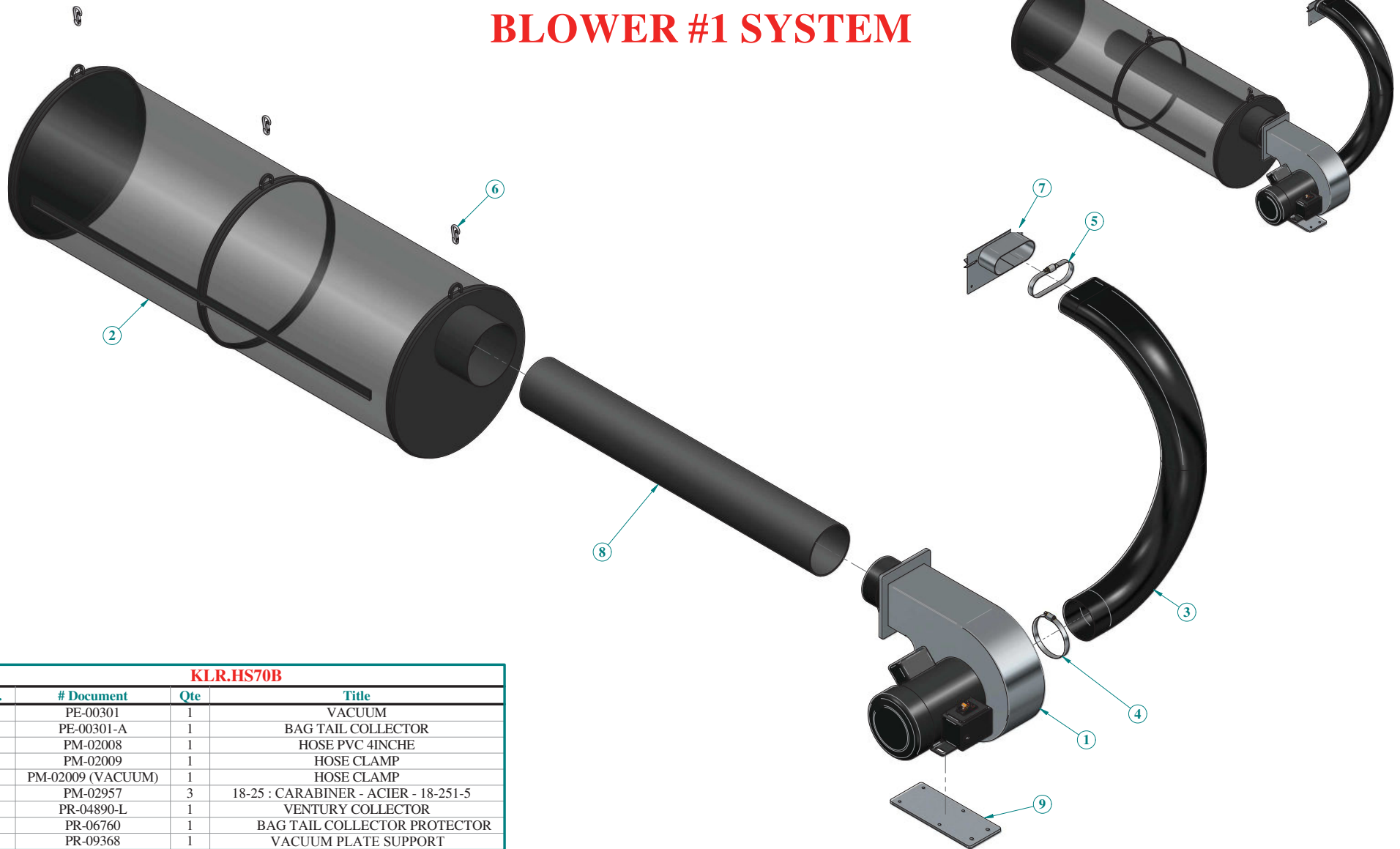

KLR.HS70B			
No.	# Document	Qty	Title
1	PE-00301	1	VACUUM
2	PE-00301-A	1	BAG TAIL COLLECTOR
3	PM-02008	1	HOSE PVC 4INCHE
4	PM-02009	1	HOSE CLAMP
5	PM-02009 (VACUUM)	1	HOSE CLAMP
6	PM-02957	3	18-25 : CARABINER - ACIER - 18-251-5
7	PR-04890-L	1	VENTURY COLLECTOR
8	PR-06760	1	BAG TAIL COLLECTOR PROTECTOR
9	PR-09368	1	VACUUM PLATE SUPPORT



**BLOWER 2 OPTION**

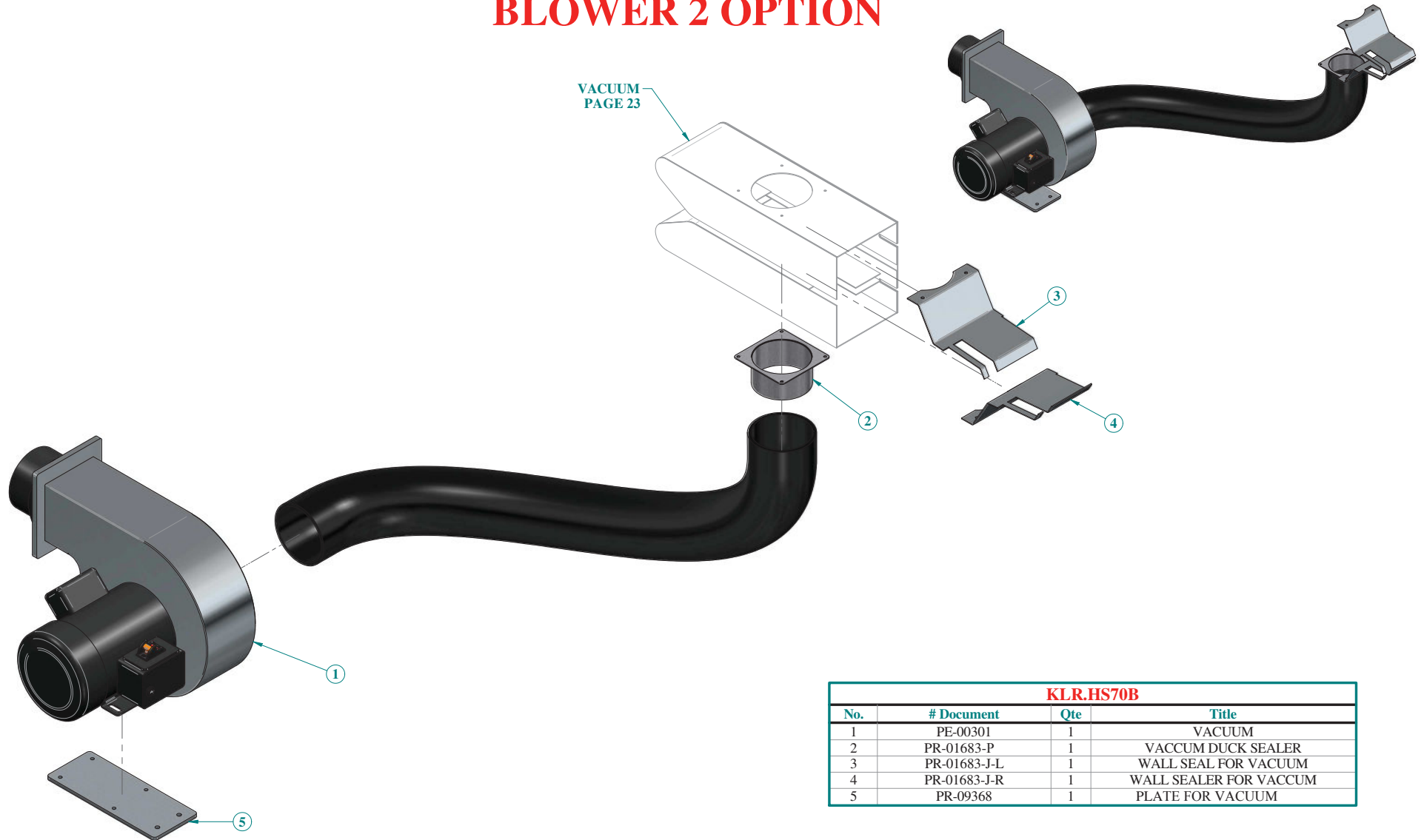

<b>KLR.HS70B</b>			
<b>No.</b>	<b># Document</b>	<b>Qty</b>	<b>Title</b>
1	PE-00301	1	VACUUM
2	PR-01683-P	1	VACCUM DUCK SEALER
3	PR-01683-J-L	1	WALL SEAL FOR VACUUM
4	PR-01683-J-R	1	WALL SEALER FOR VACCUM
5	PR-09368	1	PLATE FOR VACUUM



# SEALER

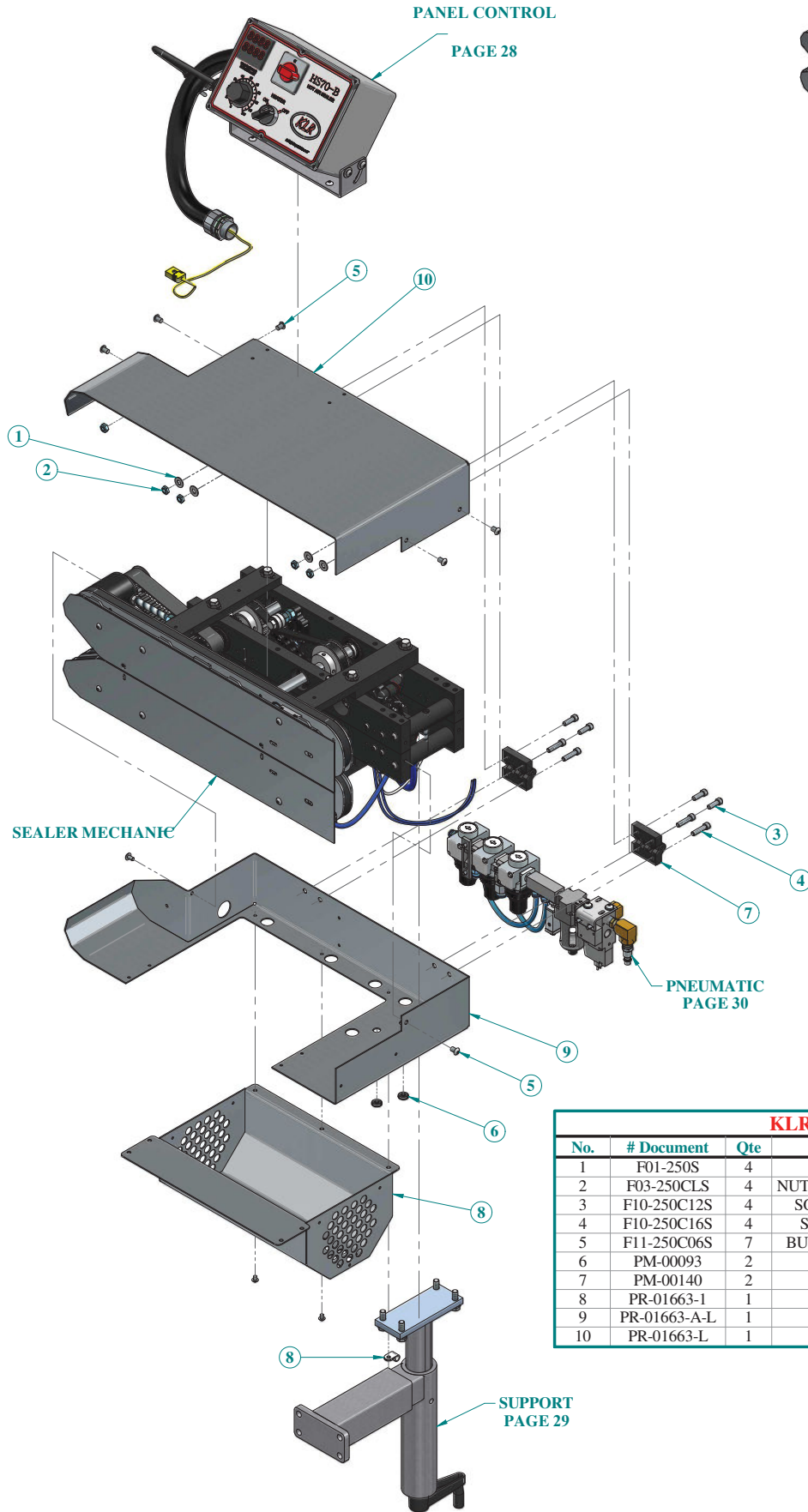
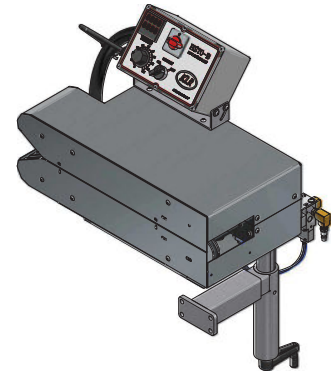

KLR.HS70B			
No.	# Document	Qty	Title
1	F01-250S	4	FLAT WASHER # 14 STAINLESS
2	F03-250CLS	4	NUT HEX 1/4-20 LOW PROFILE STAINLESS
3	F10-250C12S	4	SOCKET CAP 1/4-20 X 3/4" STAINLESS
4	F10-250C16S	4	SOCKET CAP 1/4-20 X 1" STAINLESS
5	F11-250C06S	7	BUTTON HEAD 1/4-20 X 3/8" STAINLESS
6	PM-00093	2	GUIDE WIRE
7	PM-00140	2	HINGE
8	PR-01663-1	1	MOTOR GUARD
9	PR-01663-A-L	1	LOWER COVER
10	PR-01663-L	1	TOP COVER

**SYSTEMES  SYSTEMS Inc**  
**PANEL CONTROL**

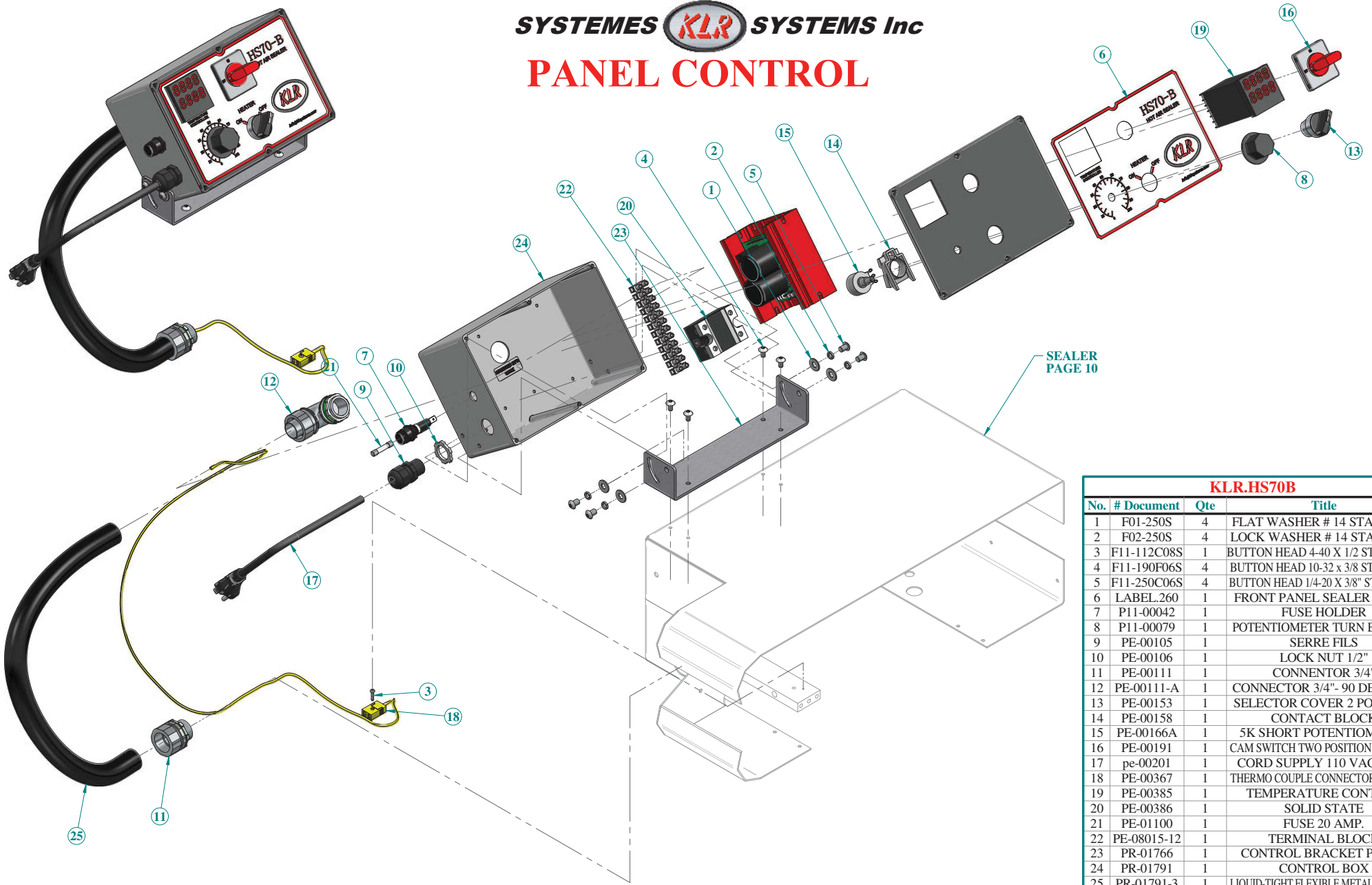

SEALER  
PAGE 10

KLR.HS70B				
No. #	Document	Qty	Title	
1	F01-250S	4	FLAT WASHER # 14 STAINLESS	
2	F02-250S	4	LOCK WASHER # 14 STAINLESS	
3	F11-112C08S	1	BUTTON HEAD 4-40 X 1/2 STAINLESS	
4	F11-190F06S	4	BUTTON HEAD 10-32 x 3/8 STAINLESS	
5	F11-250C06S	4	BUTTON HEAD 1/4-20 X 3/8" STAINLESS	
6	LABEL.260	1	FRONT PANEL SEALER LABEL	
7	P11-00042	1	FUSE HOLDER	
8	P11-00079	1	POTENTIOMETER TURN BUTTON	
9	PE-00105	1	SERRE FILS	
10	PE-00106	1	LOCK NUT 1/2"	
11	PE-00111	1	CONNENTOR 3/4"	
12	PE-00111-A	1	CONNECTOR 3/4"- 90 DEGREES	
13	PE-00153	1	SELECTOR COVER 2 POSITION	
14	PE-00158	1	CONTACT BLOCK	
15	PE-00166A	1	5K SHORT POTENTIOMETER	
16	pe-00191	1	CAM SWITCH TWO POSITION (ON/OFF)	
17	pe-00201	1	CORD SUPPLY 110 VAC 16GA	
18	PE-00367	1	THERMO COUPLE CONNECTOR FEMALE	
19	PE-00385	1	TEMPERATURE CONTROL	
20	PE-00386	1	SOLID STATE	
21	PE-01100	1	FUSE 20 AMP.	
22	PE-08015-12	1	TERMINAL BLOCK	
23	PR-01766	1	CONTROL BRACKET PANEL	
24	PR-01791	1	CONTROL BOX	
25	PR-01791-3	1	LIQUID-TIGHT FLEXIBLE METAL CONDUIT	

# SUPPORT

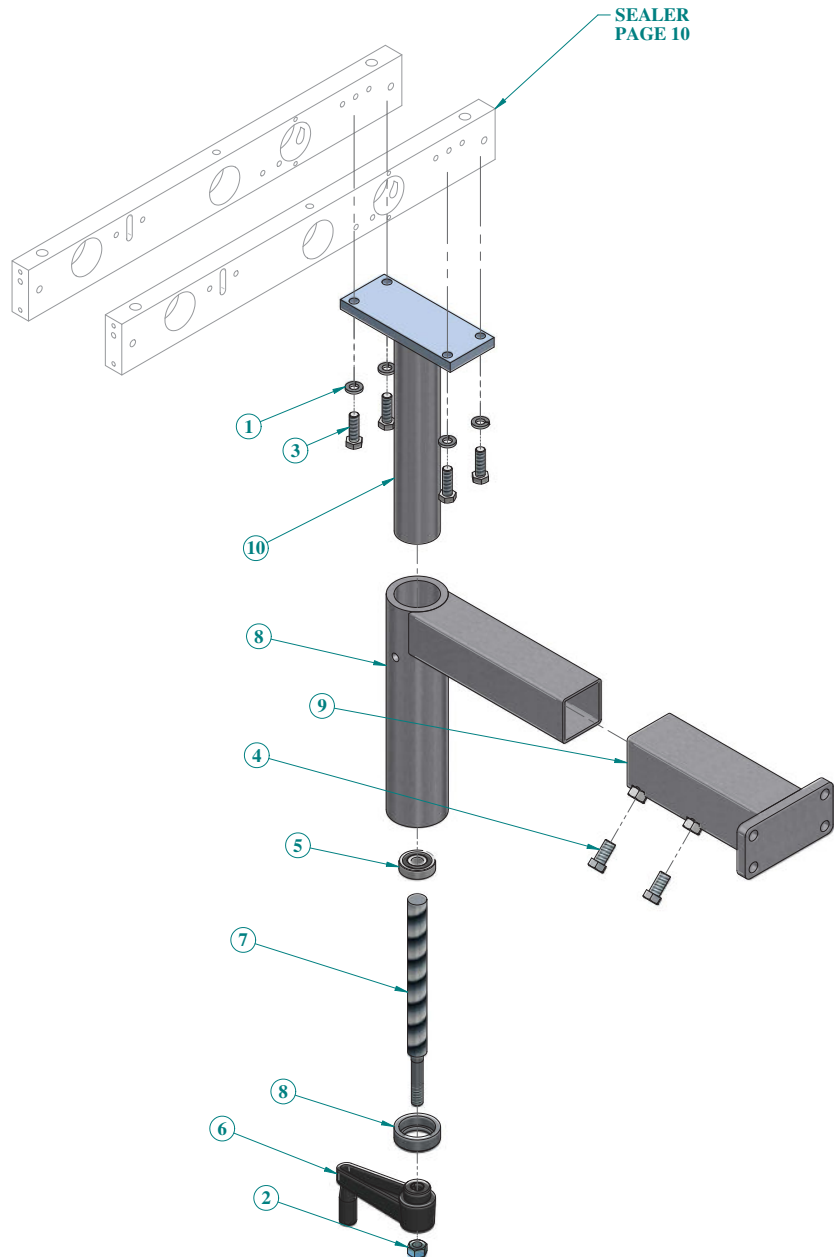
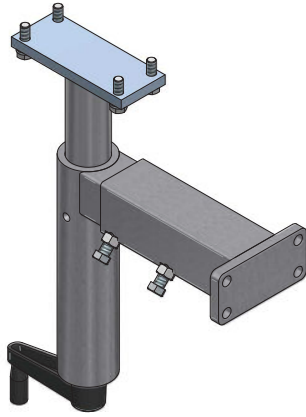

KLR.HS70B			
No.	# Document	Qty	Title
1	F02-312S	4	LOCK WASHER 5/16" STAINLESS
2	F03-375C	1	HEX NUT 3/8-16 ZINC
3	F13-312C16S	4	HEX HEAD 5/16-18 X 1" STAINLESS
4	F13-375C12S	2	HEX HEAD 3/8-16 X 3/4" STAINLESS
5	PM-00106	1	BEARING
6	PR-01065-A	1	CRANK HANDLE
7	pr-01609	1	5/8 ACME THREAD ROD
8	PR-01624	1	SEALER BRACKET FEMALE
9	PR-01625	1	BRACKET SUPPORT
10	PR-01699-1	1	BRACKET SUPPORT

**SYSTEMES  SYSTEMS Inc**  
**PNEUMATIC**

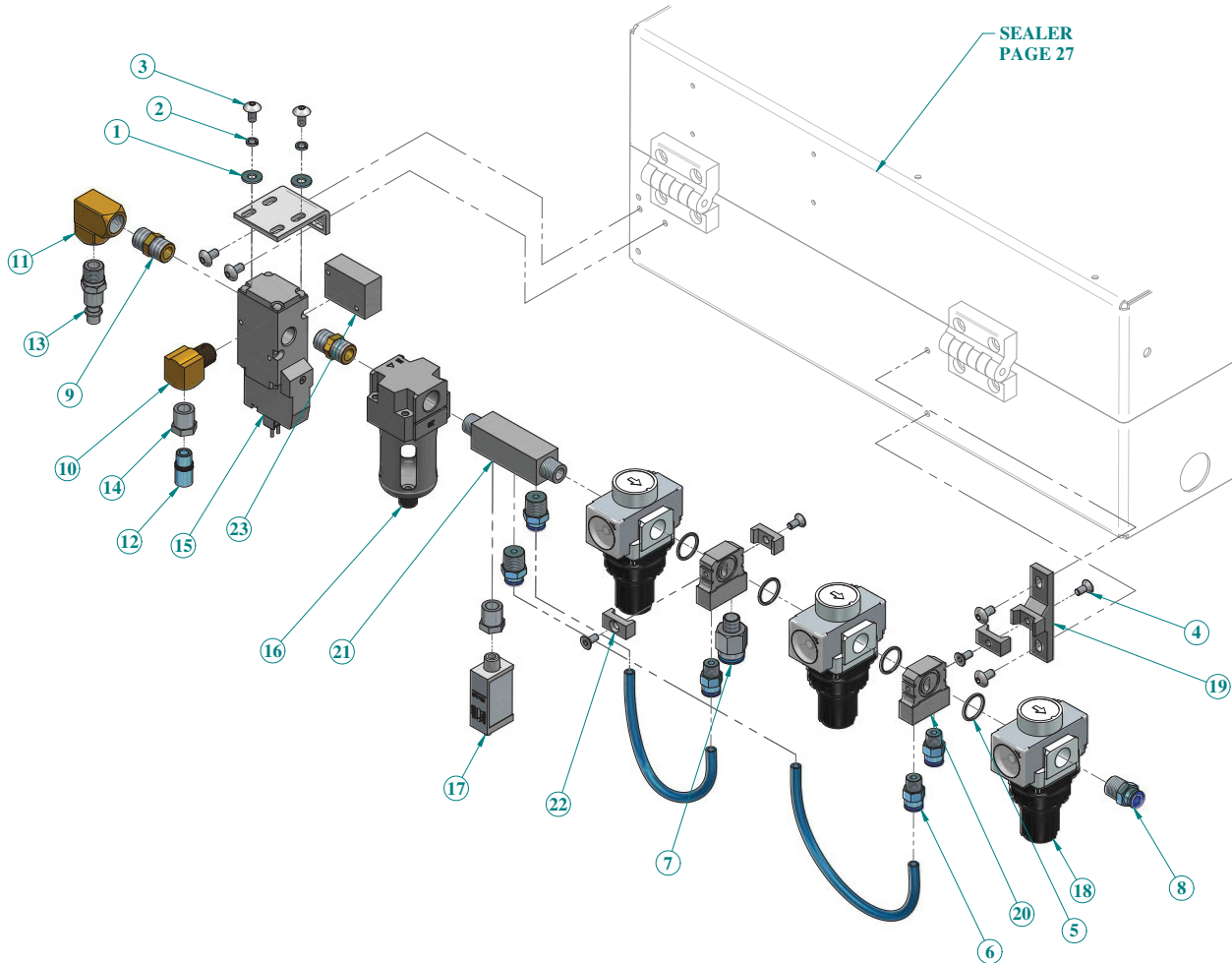
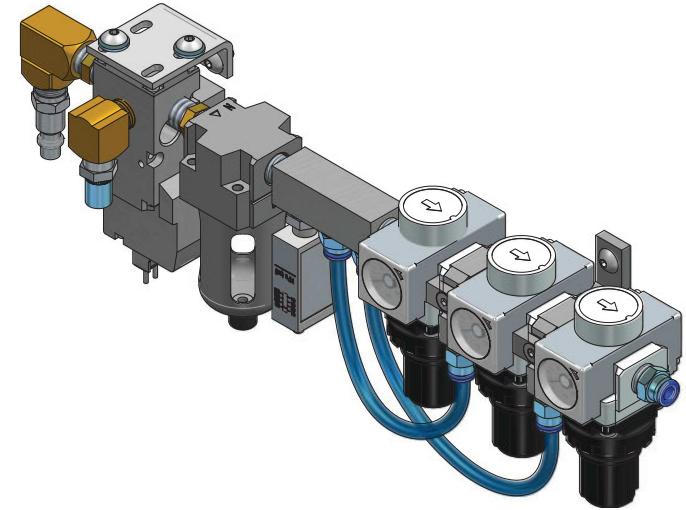

KLR.HS70B			
No.	# Document	Qty	Title
1	F01-190S	2	FLAT WASHER #10 STAINLESS
2	F02-190S	2	LOCK WASHER #10 STAINLESS
3	F11-190F06S	6	BUTTON HEAD 10-32 x 3/8 STAINLESS
4	F12-164C06S	4	FLAT HEAD 8-32 X 3/8 STAINLESS
5	PM-02984	4	O-RING FOR AIR TREATMENT
6	PP-00151	3	UNION CONNECTOR 1/4 TUB - 1/8 NPT
7	PP-00152	1	UNION CONN 3/8 TUBE X 1/8 NPT
8	PP-00159	3	CONNECTOR UNION 1/4 TUB - 1/4 NPT
9	PP-00164	2	UNION MALA/MALE 1/4 NPT-1/4 NPT
10	PP-00166	1	90 ELBOW 1/4 NPT F / 1/4 NPT M
11	PP-00172	1	90 ELBOW 1/4 X 1/4 FEM/FEM
12	PP-00185	1	MUFFLER 1/8 NPT
13	PP-00194	1	QUICK COUPLERS 1/4 NPT MALE
14	PP-00204	2	REDUCER 1/8-1/4 BRASS FEM/MALE
15	PP-00599	1	AIR VALV 110-115 VAC 60 HZ
16	PP-00691	1	AIR PREP TREATMENT FILTER
17	PP-00692	1	PRESSURE SWITCH
18	PP-00693	3	AIR PREP TREATMENT
19	PP-00695 (MOD)	1	COUPLER
20	PR-01797	2	REGULATOR SUPPLY BLOCK
21	PR-01798	1	MANIFOLD SEALER
22	PR-01799	2	HOLDER BRACKET
23	PR-01845	1	SHIM

# SEALER MECHANIC

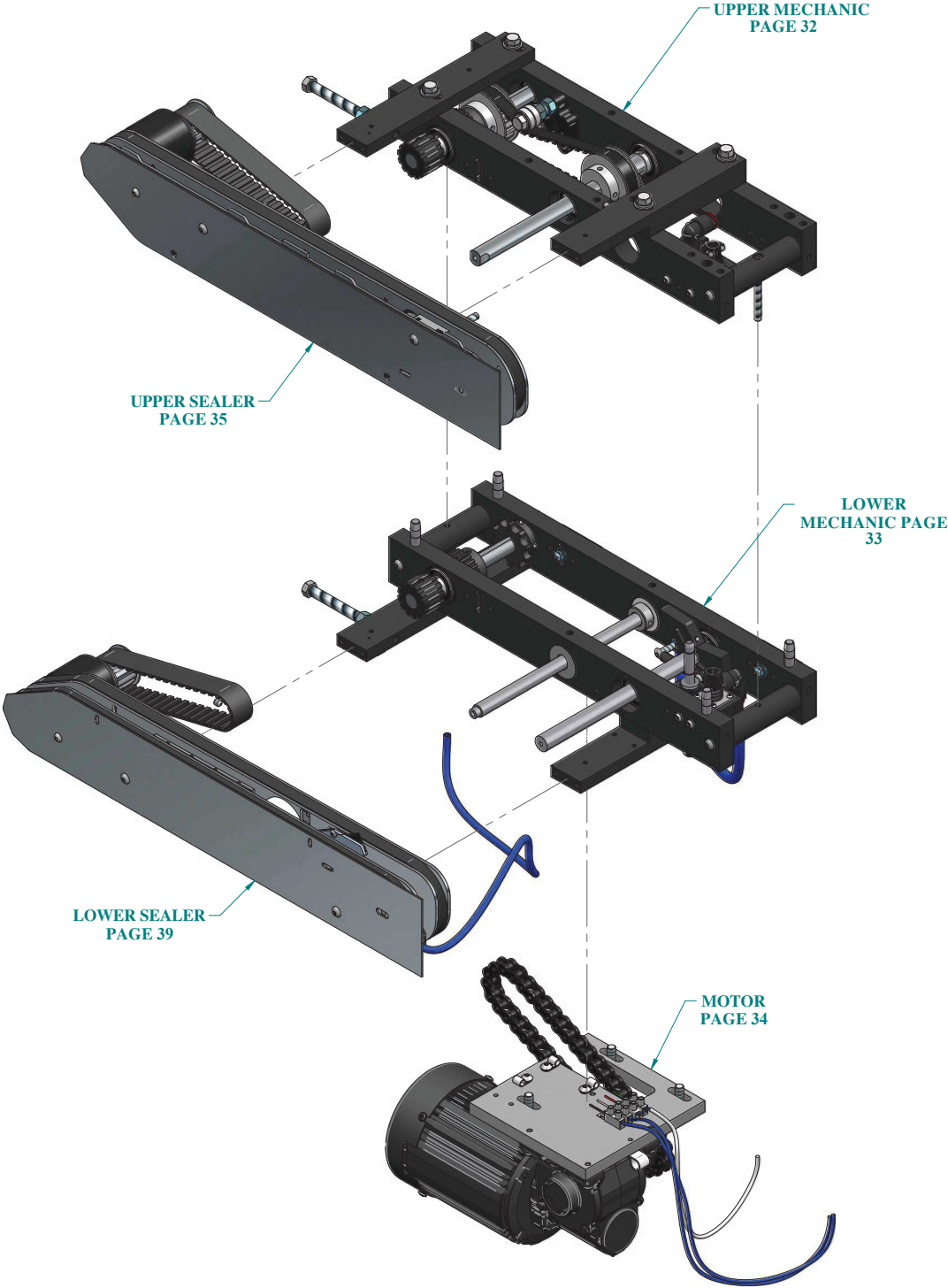
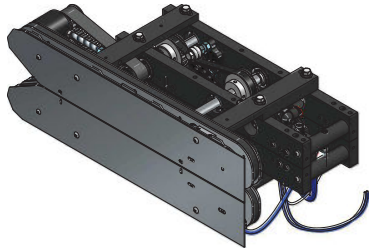



# UPPER MECHANIC

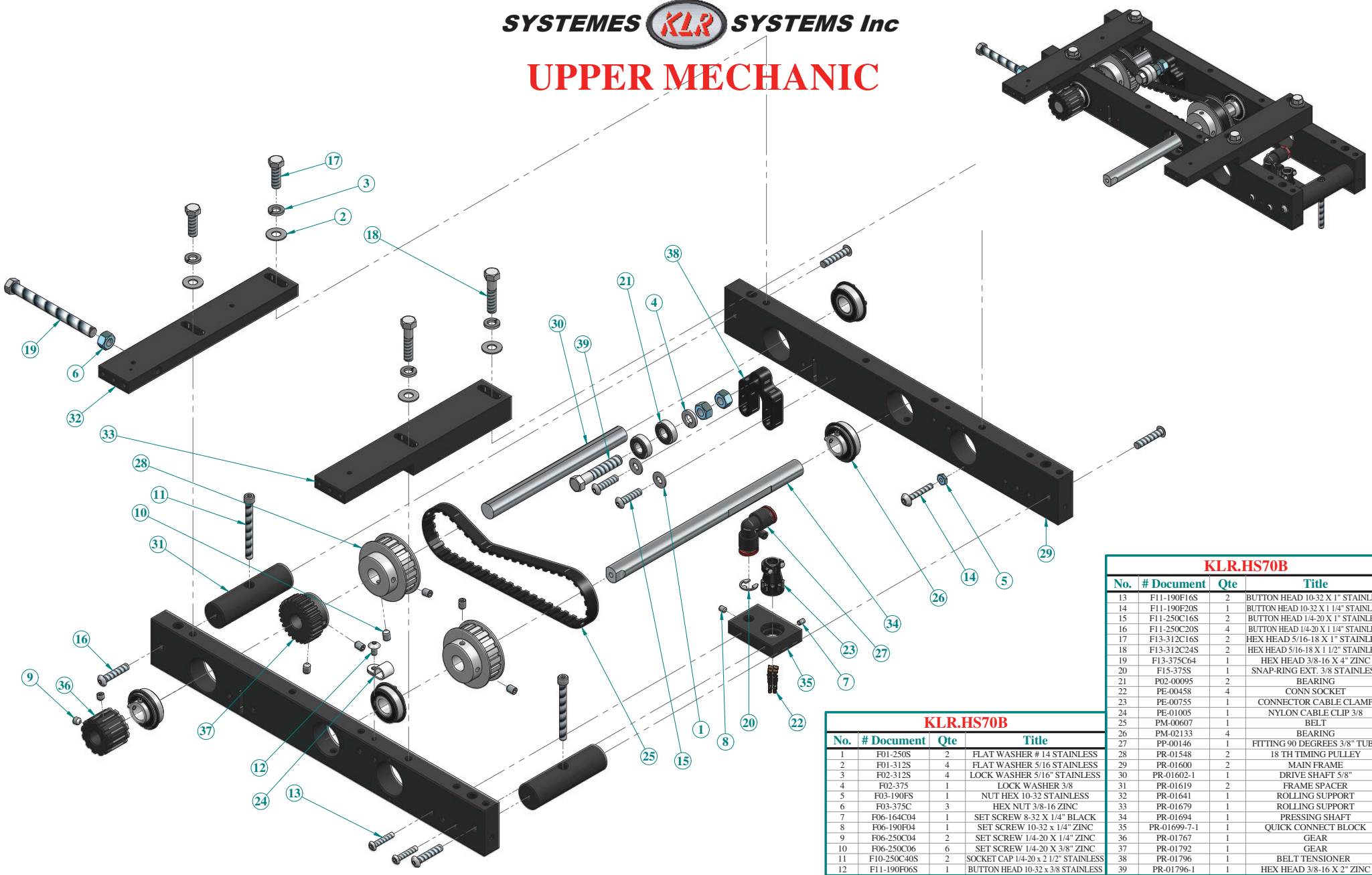

**KLR.HS70B**

No.	# Document	Qty	Title
13	F11-190F16S	2	BUTTON HEAD 10-32 X 1" STAINLESS
14	F11-190F20S	1	BUTTON HEAD 10-32 X 1 1/4" STAINLESS
15	F11-250C16S	2	BUTTON HEAD 1/4-20 X 1" STAINLESS
16	F11-250C20S	4	BUTTON HEAD 1/4-20 X 1 1/4" STAINLESS
17	F13-312C16S	2	HEX HEAD 5/16-18 X 1" STAINLESS
18	F13-312C24S	2	HEX HEAD 5/16-18 X 1 1/2" STAINLESS
19	F13-375C64	1	HEX HEAD 3/8-16 X 4" ZINC
20	F15-375S	1	SNAP-RING EXT. 3/8" STAINLESS
21	P02-00095	2	BEARING
22	PE-00458	4	CONN SOCKET
23	PE-00755	1	CONNECTOR CABLE CLAMP
24	PE-01005	1	NYLON CABLE CLIP 3/8"
25	PM-00607	1	BELT
26	PM-02133	4	BEARING
27	PP-00146	1	FITTING 90 DEGREES 3/8" TUBE
28	PR-01548	2	18 TH TIMING PULLEY
29	PR-01600	2	MAIN FRAME
30	PR-01602-1	1	DRIVE SHAFT 5/8"
31	PR-01619	2	FRAME SPACER
32	PR-01641	1	ROLLING SUPPORT
33	PR-01679	1	ROLLING SUPPORT
34	PR-01694	1	PRESSING SHAFT
35	PR-01699-7-1	1	QUICK CONNECT BLOCK
36	PR-01767	1	GEAR
37	PR-01792	1	GEAR
38	PR-01796	1	BELT TENSIONER
39	PR-01796-1	1	HEX HEAD 3/8-16 X 2" ZINC

**KLR.HS70B**

No.	# Document	Qty	Title
1	F01-250S	2	FLAT WASHER # 14 STAINLESS
2	F01-312S	4	FLAT WASHER 5/16 STAINLESS
3	F02-312S	4	LOCK WASHER 5/16" STAINLESS
4	F02-375	1	LOCK WASHER 3/8"
5	F03-190FS	1	NUT HEX 10-32 STAINLESS
6	F03-375C	3	HEX NUT 3/8-16 ZINC
7	F06-164C04	1	SET SCREW 8-32 X 1/4" BLACK
8	F06-190F04	1	SET SCREW 10-32 x 1/4" ZINC
9	F06-250C04	2	SET SCREW 1/4-20 X 1/4" ZINC
10	F06-250C06	6	SET SCREW 1/4-20 X 3/8" ZINC
11	F10-250C40S	2	SOCKET CAP 1/4-20 x 2 1/2" STAINLESS
12	F11-190F06S	1	BUTTON HEAD 10-32 x 3/8 STAINLESS

**SYSTEMES  SYSTEMS Inc**  
**LOWER MECANIC**

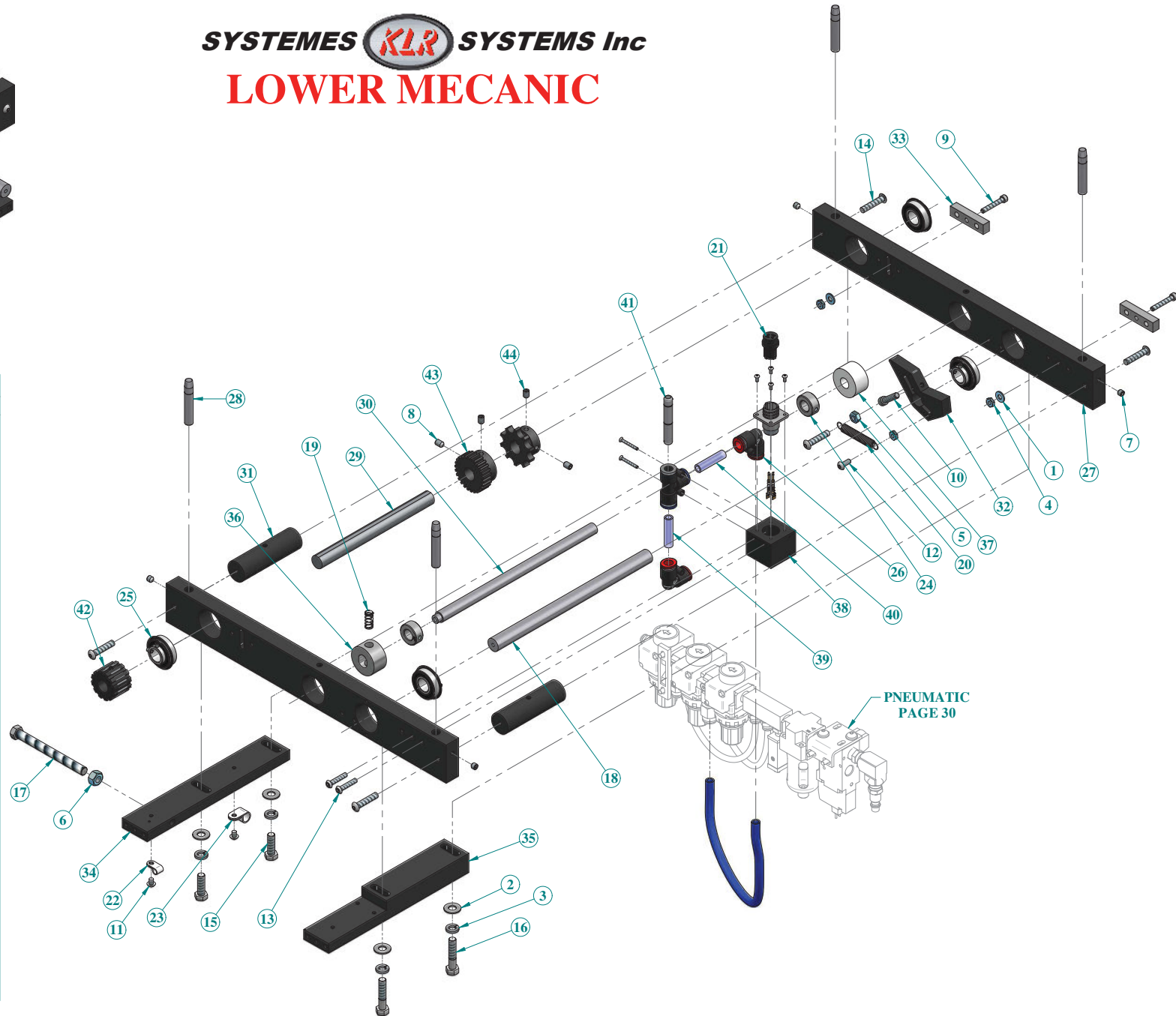
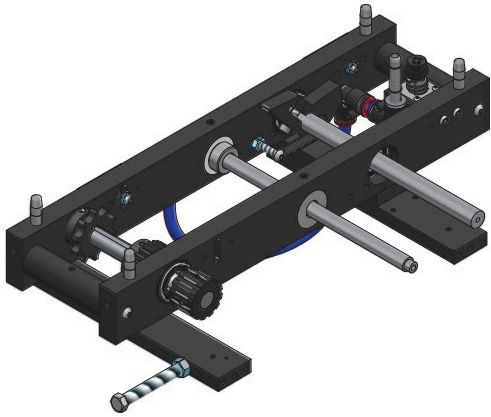

**KLR.HS70B**

No.	# Document	Qty	Title
1	F01-190S	2	FLAT WASHER #10 STAINLESS
2	F01-312S	4	FLAT WASHER 5/16" STAINLESS
3	F02-312S	4	LOCK WASHER 5/16" STAINLESS
4	F03-190FS	3	NUT HEX 10-32 STAINLESS
5	F03-250CS	1	NUT HEX. 1/4-20 STAINLESS
6	F03-375C	1	HEX NUT 3/8-16 ZINC
7	F06-250C04	4	SET SCREW 1/4-20 X 1/4" ZINC
8	F06-250C06	2	SET SCREW 1/4-20 X 3/8" ZINC
9	F10-190F20S	2	SOCKET CAP 10-32 X 1 1/4" STAINLESS
10	F10-250C16S	1	SOCKET CAP 1/4-20 X 1" STAINLESS
11	F11-190F04S	2	BUTTON HEAD 10-32 x 1/4" STAINLESS
12	F11-190F08S	1	BUTTON HEAD 10-32 X 1/2" STAINLESS
13	F11-190F16S	2	BUTTON HEAD 10-32 X 1" STAINLESS
14	F11-250C20S	5	BUTTON HEAD 1/4-20 X 1 1/4" STAINLESS
15	F13-312C16S	2	HEX HEAD 5/16-18 X 1" STAINLESS
16	F13-312C24S	2	HEX HEAD 5/16-18 X 1 1/2" STAINLESS
17	F13-375C64	1	HEX HEAD 3/8-16 X 4" ZINC
18	KR-01770	1	KNIFE SHAFT KIT
19	OS-0045	1	COMPRESSION SPRING
20	OS-043 (SEALER)	1	SPRING
21	PE-00314-M	1	PLUG (AMP)
22	PE-01002	1	NYLON CABLE CLAMP
23	PE-01005	1	NYLON CABLE CLIP 3/8
24	PM-00252	2	SHAFT COLLAR 1/2"
25	PM-02133	4	BEARING
26	PP-00146	2	FITTING 90 DEGREES 3/8" TUBE
27	PR-01600	2	MAIN FRAME
28	PR-01601	4	DOWEL
29	PR-01602-1	1	DRIVE SHAFT 5/8"
30	PR-01603	1	IDLER PRESSURE ROLL SHAFT
31	PR-01620	2	FRAME SPACER
32	PR-01623	1	KNIFE PIVOT BLOCK
33	PR-01628	2	SHIM
34	PR-01641	1	ROLLING SUPPORT
35	PR-01679-1	1	ROLLING SUPPORT
36	PR-01687	1	SET BUSHING
37	PR-01693	1	BUSHING
38	PR-01697	1	BLOCK SUPPORT ASSEMBLY
39	PR-01697-2	1	PNEUMATIC TUBE
40	PR-01697-3	1	PNEUMATIC TUBE
41	PR-01699-8	1	STAINLESS TUBE
42	PR-01767	1	GEAR
43	PR-01792	1	GEAR
44	SSB40-10KK	1	SPROCKET

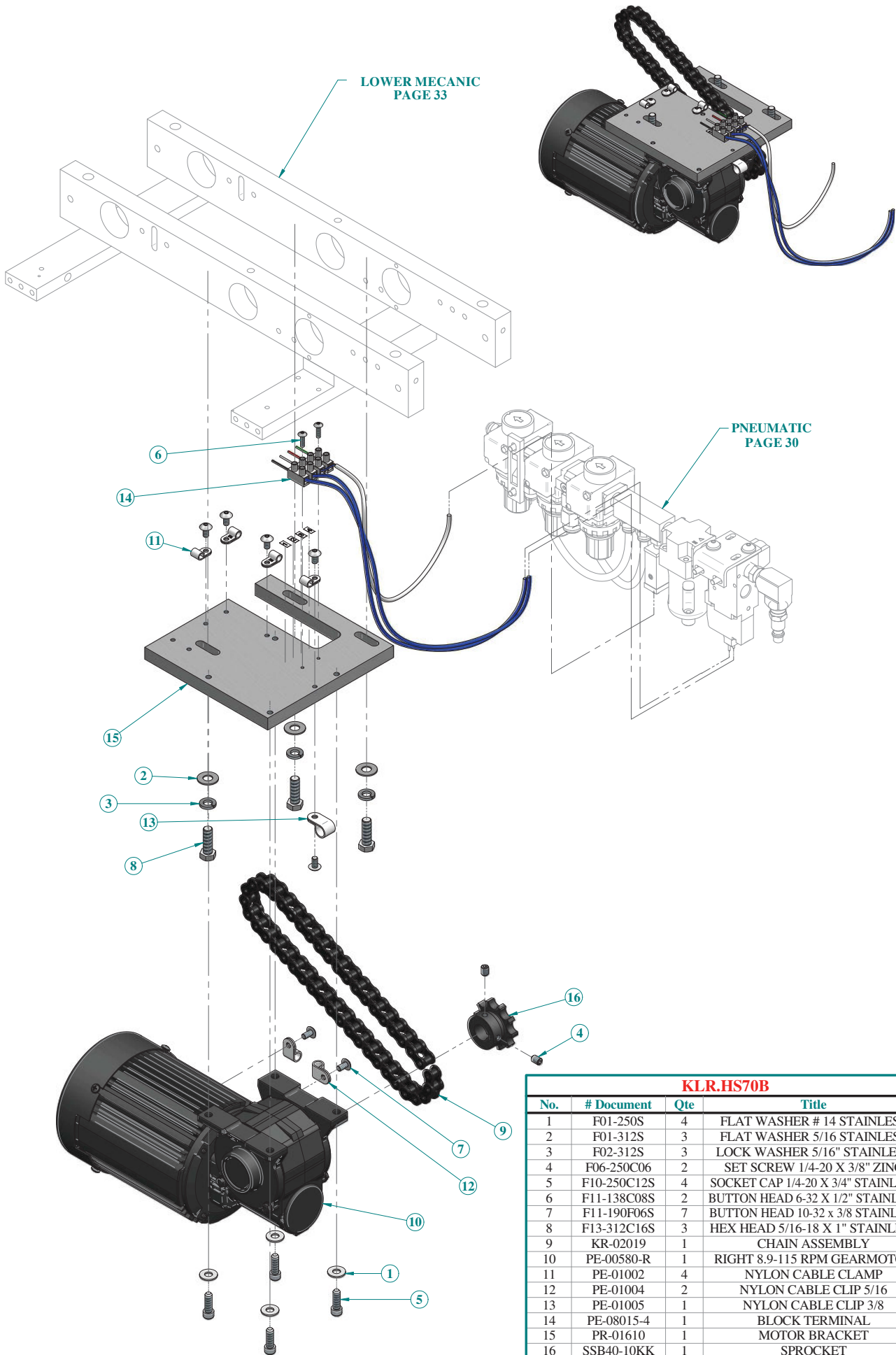

KLR.HS70B			
No.	# Document	Qty	Title
1	F01-250S	4	FLAT WASHER # 14 STAINLESS
2	F01-312S	3	FLAT WASHER 5/16 STAINLESS
3	F02-312S	3	LOCK WASHER 5/16" STAINLESS
4	F06-250C06	2	SET SCREW 1/4-20 X 3/8" ZINC
5	F10-250C12S	4	SOCKET CAP 1/4-20 X 3/4" STAINLESS
6	F11-138C08S	2	BUTTON HEAD 6-32 X 1/2" STAINLESS
7	F11-190F06S	7	BUTTON HEAD 10-32 x 3/8 STAINLESS
8	F13-312C16S	3	HEX HEAD 5/16-18 X 1" STAINLESS
9	KR-02019	1	CHAIN ASSEMBLY
10	PE-00580-R	1	RIGHT 8.9-115 RPM GEARMOTOR
11	PE-01002	4	NYLON CABLE CLAMP
12	PE-01004	2	NYLON CABLE CLIP 5/16
13	PE-01005	1	NYLON CABLE CLIP 3/8
14	PE-08015-4	1	BLOCK TERMINAL
15	PR-01610	1	MOTOR BRACKET
16	SSB40-10KK	1	SPROCKET



**SYSTEMES *KLR* SYSTEMS Inc**  
**UPPER SEALER**

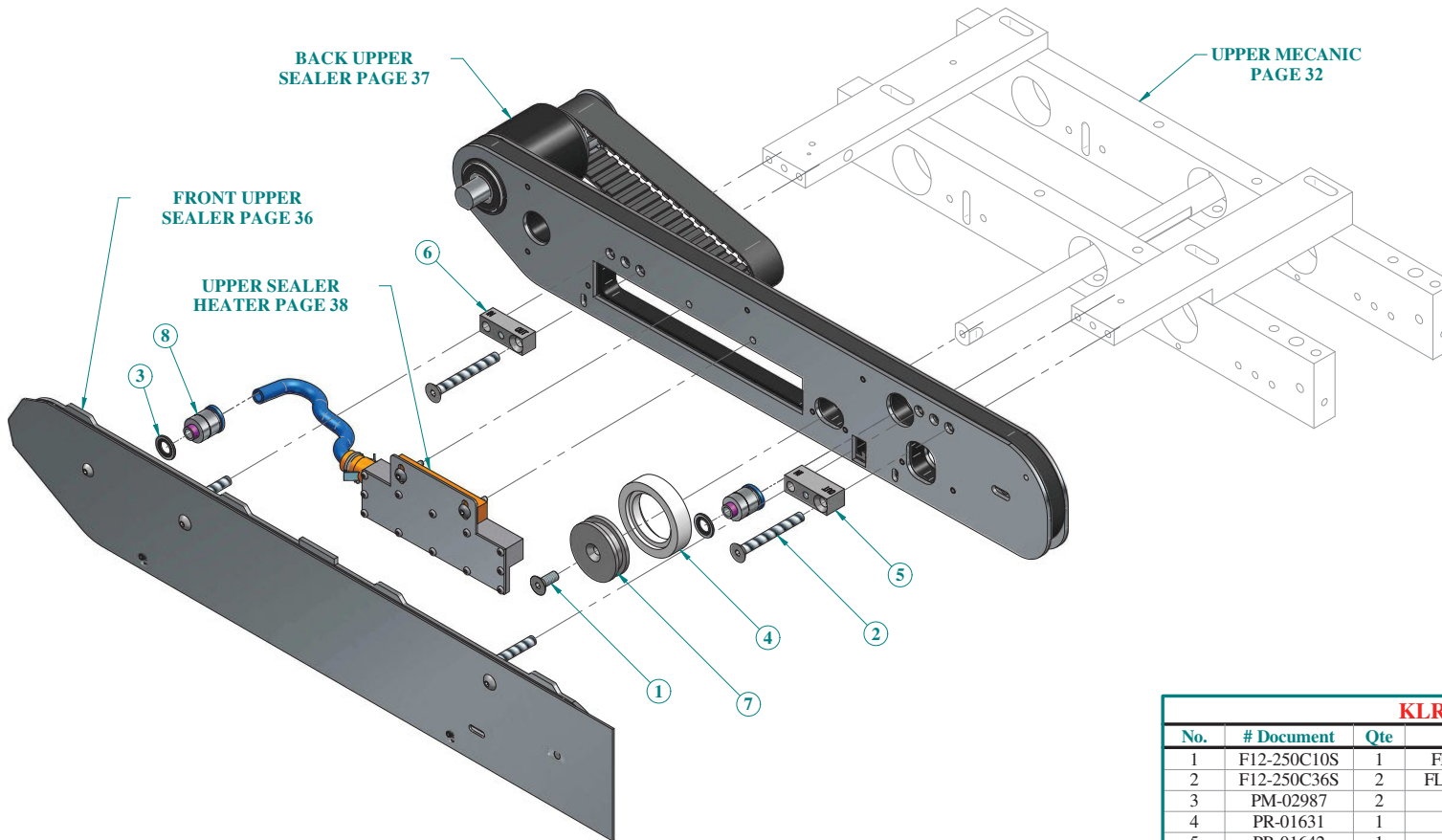

<b>KLR.HS70B</b>			
No.	# Document	Qty	Title
1	F12-250C10S	1	FLAT HEAD 1/4-20 X 5/8" STAINLESS
2	F12-250C36S	2	FLAT HEAD 1/4-20 X 2 1/4" STAINLESS
3	PM-02987	2	PRESSURE SEALING WASHER 3/8
4	PR-01631	1	PRESSURE WHEEL
5	PR-01642	1	SHIM
6	pr-01686	1	SHIM
7	PR-01695	1	DRIVE PRESSURE ROLL
8	PR-01786	2	AIR FITTING

**SYSTEMES  SYSTEMS Inc**  
**FRONT UPPER SEALER**

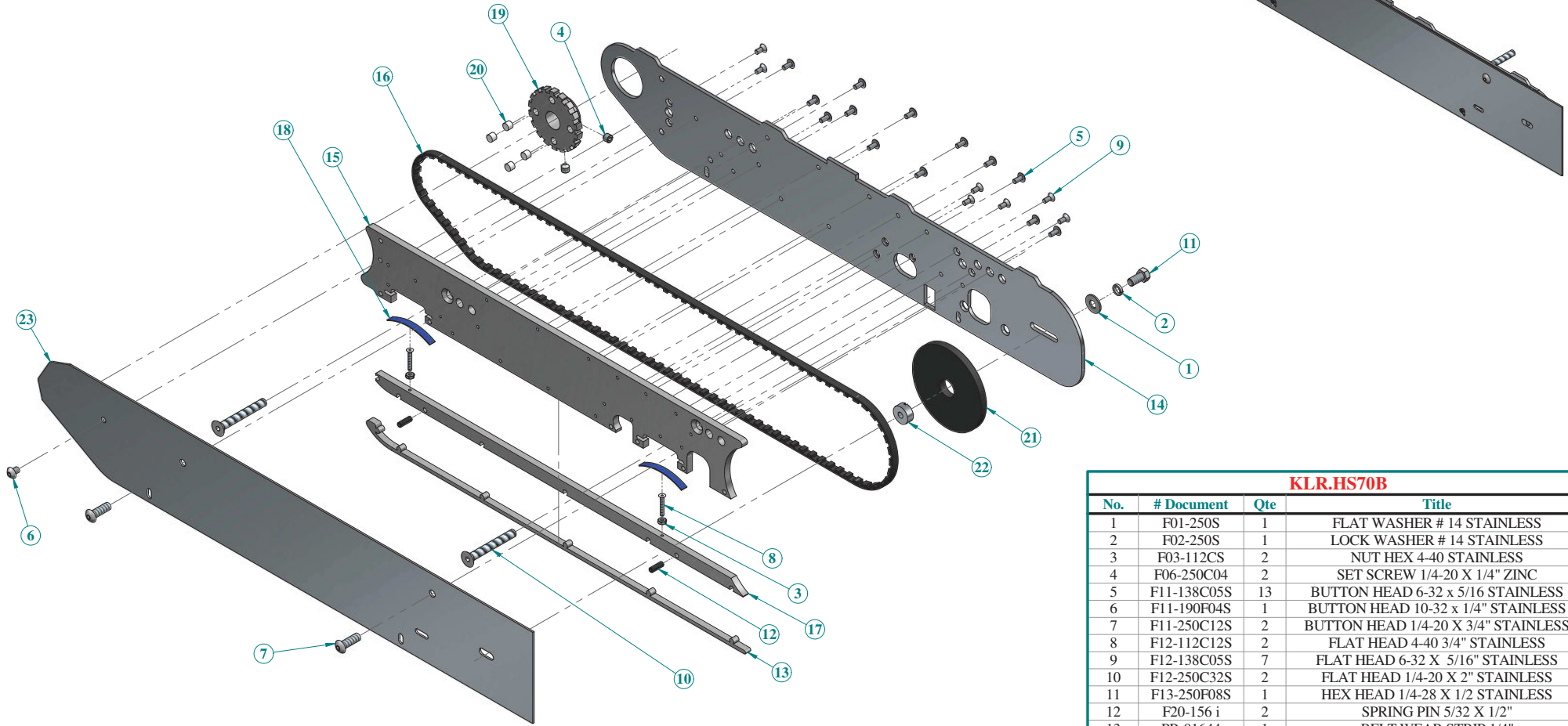

<b>KLR.HS70B</b>			
No.	# Document	Qty	Title
1	F01-250S	1	FLAT WASHER # 14 STAINLESS
2	F02-250S	1	LOCK WASHER # 14 STAINLESS
3	F03-112CS	2	NUT HEX 4-40 STAINLESS
4	F06-250C04	2	SET SCREW 1/4-20 X 1/4" ZINC
5	F11-138C05S	13	BUTTON HEAD 6-32 x 5/16 STAINLESS
6	F11-190F04S	1	BUTTON HEAD 10-32 x 1/4" STAINLESS
7	F11-250C12S	2	BUTTON HEAD 1/4-20 X 3/4" STAINLESS
8	F12-112C12S	2	FLAT HEAD 4-40 3/4" STAINLESS
9	F12-138C05S	7	FLAT HEAD 6-32 X 5/16" STAINLESS
10	F12-250C32S	2	FLAT HEAD 1/4-20 X 2" STAINLESS
11	F13-250F08S	1	HEX HEAD 1/4-28 X 1/2" STAINLESS
12	F20-156 i	2	SPRING PIN 5/32 X 1/2"
13	PR-01644	1	BELT WEAR STRIP 1/4"
14	PR-01647	1	THIN BELT HOLDER PLATE
15	PR-01652-G	1	PRESSURE WHEEL
16	PR-01667	1	BELT
17	PR-01673	1	BELT PRESSURE BAR 1/4
18	PR-01674-E	2	SPRING STEEL
19	PR-01676	1	18TH TIMING PULLEY
20	PR-01676-A	4	PIN
21	PR-01677	1	WHEEL TENDER
22	PR-01680	1	SPACER
23	PR-01683-L	1	TOP SIDE FRAME

**SYSTEMES *KLR* SYSTEMS Inc**  
**BACK UPPER SEALER**

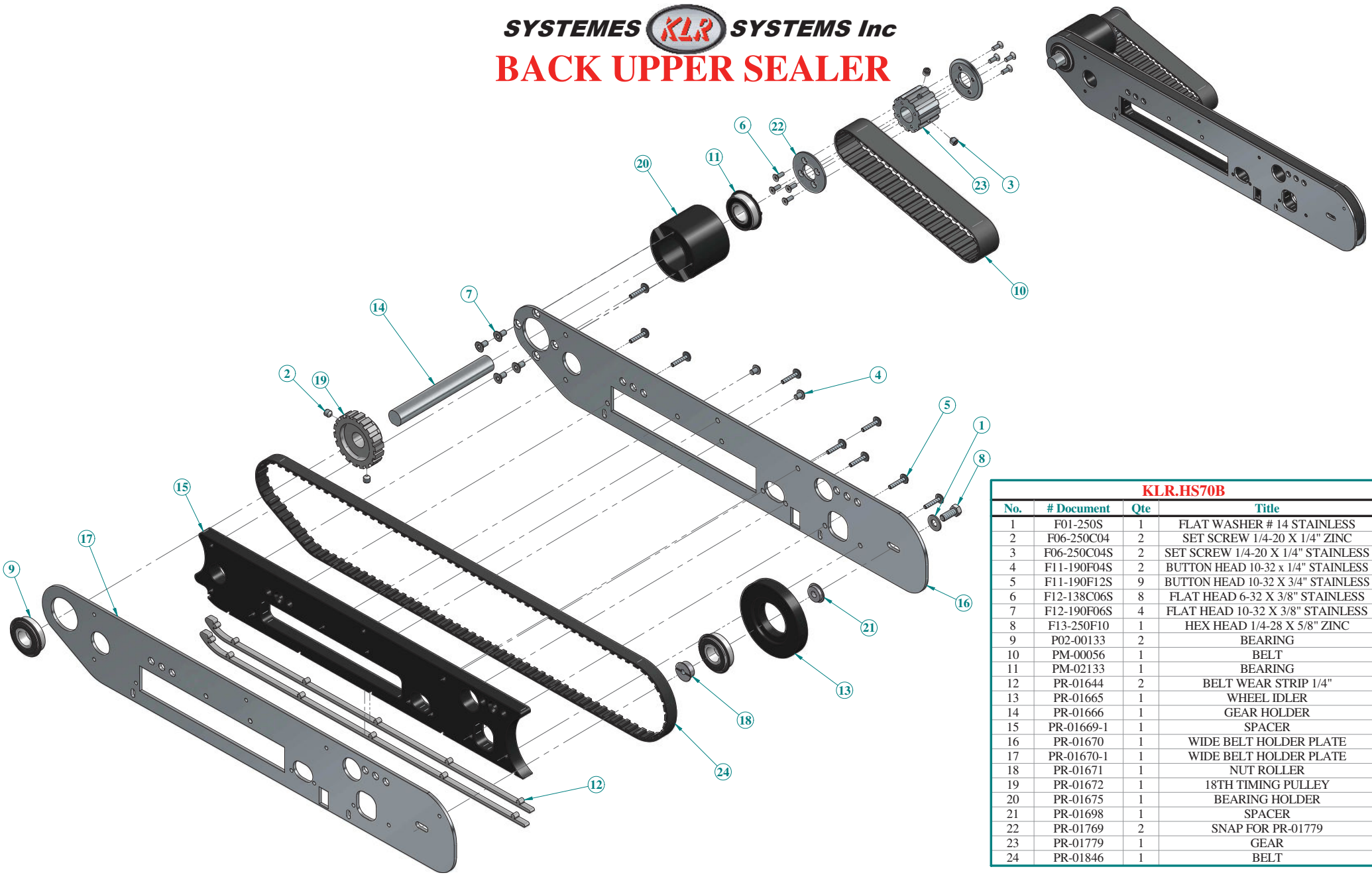

<b>KLR.HS70B</b>			
No.	# Document	Qty	Title
1	F01-250S	1	FLAT WASHER # 14 STAINLESS
2	F06-250C04	2	SET SCREW 1/4-20 X 1/4" ZINC
3	F06-250C04S	2	SET SCREW 1/4-20 X 1/4" STAINLESS
4	F11-190F04S	2	BUTTON HEAD 10-32 x 1/4" STAINLESS
5	F11-190F12S	9	BUTTON HEAD 10-32 X 3/4" STAINLESS
6	F12-138C06S	8	FLAT HEAD 6-32 X 3/8" STAINLESS
7	F12-190F06S	4	FLAT HEAD 10-32 X 3/8" STAINLESS
8	F13-250F10	1	HEX HEAD 1/4-28 X 5/8" ZINC
9	P02-00133	2	BEARING
10	PM-00056	1	BELT
11	PM-02133	1	BEARING
12	PR-01644	2	BELT WEAR STRIP 1/4"
13	PR-01665	1	WHEEL IDLER
14	PR-01666	1	GEAR HOLDER
15	PR-01669-1	1	SPACER
16	PR-01670	1	WIDE BELT HOLDER PLATE
17	PR-01670-1	1	WIDE BELT HOLDER PLATE
18	PR-01671	1	NUT ROLLER
19	PR-01672	1	18TH TIMING PULLEY
20	PR-01675	1	BEARING HOLDER
21	PR-01698	1	SPACER
22	PR-01769	2	SNAP FOR PR-01779
23	PR-01779	1	GEAR
24	PR-01846	1	BELT

**SYSTEMES *KLR* SYSTEMS Inc**  
**UPPER SEALER HEATER**

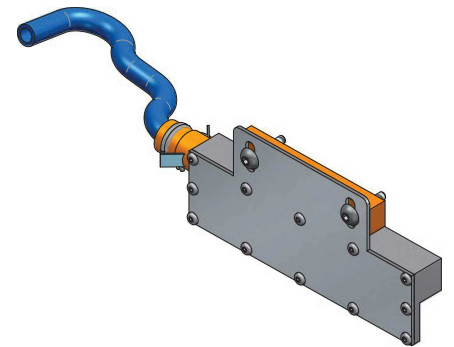
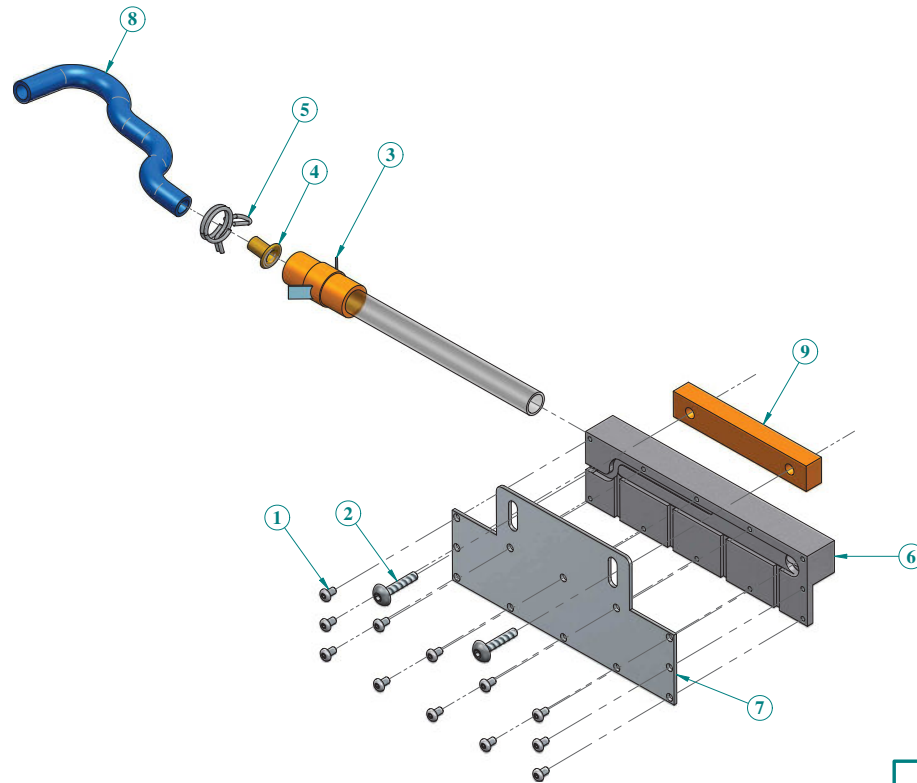

<b>KLR.HS70B</b>			
No.	# Document	Qty	Title
1	F11-112C03S	12	BUTTON HEAD 4-40 X 3/16" STAINLESS
2	F11-190F12S	2	BUTTON HEAD 10-32 X 3/4" STAINLESS
3	PE-00370	1	ELEMENT HEATER
4	PM-00326	1	EYELET
5	PM-01450	1	HOSE CLAMPS
6	PR-01614-L	1	BLOWER
7	PR-01639	1	SIDE COVER ELEMENT HEATER
8	PR-01699-5	1	HOSE
9	PR-01763	1	PHENOILIC SPACER

**SYSTEMES *KLR* SYSTEMS Inc**  
**LOWER SEALER**

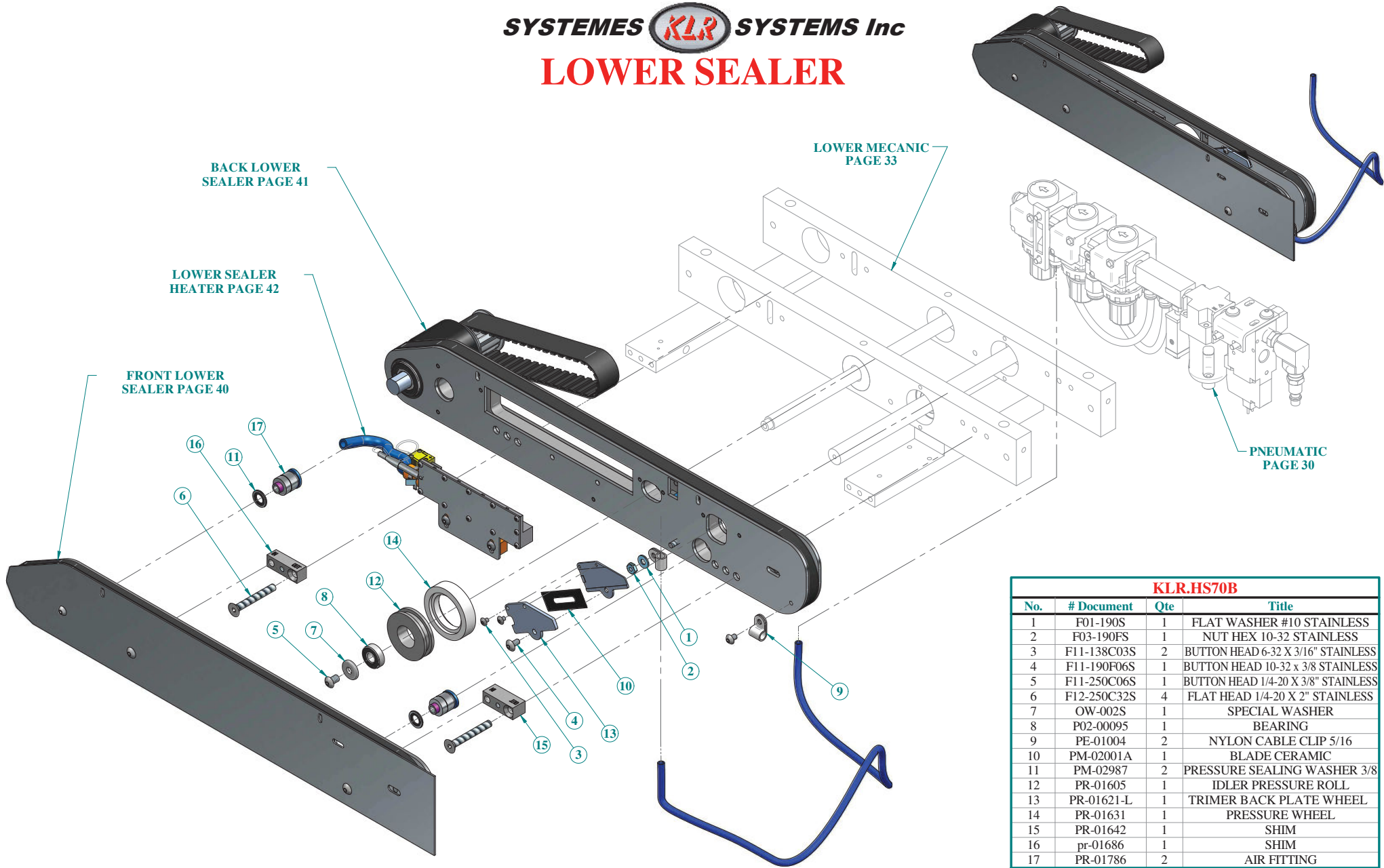

<b>KLR.HS70B</b>				
No.	# Document	Qty	Title	
1	F01-190S	1	FLAT WASHER #10 STAINLESS	
2	F03-190FS	1	NUT HEX 10-32 STAINLESS	
3	F11-138C03S	2	BUTTON HEAD 6-32 X 3/16" STAINLESS	
4	F11-190F06S	1	BUTTON HEAD 10-32 x 3/8" STAINLESS	
5	F11-250C06S	1	BUTTON HEAD 1/4-20 X 3/8" STAINLESS	
6	F12-250C32S	4	FLAT HEAD 1/4-20 X 2" STAINLESS	
7	OW-002S	1	SPECIAL WASHER	
8	P02-00095	1	BEARING	
9	PE-01004	2	NYLON CABLE CLIP 5/16	
10	PM-02001A	1	BLADE CERAMIC	
11	PM-02987	2	PRESSURE SEALING WASHER 3/8	
12	PR-01605	1	IDLER PRESSURE ROLL	
13	PR-01621-L	1	TRIMER BACK PLATE WHEEL	
14	PR-01631	1	PRESSURE WHEEL	
15	PR-01642	1	SHIM	
16	pr-01686	1	SHIM	
17	PR-01786	2	AIR FITTING	



**SYSTEMES  SYSTEMS Inc**  
**FRONT LOWER SEALER**

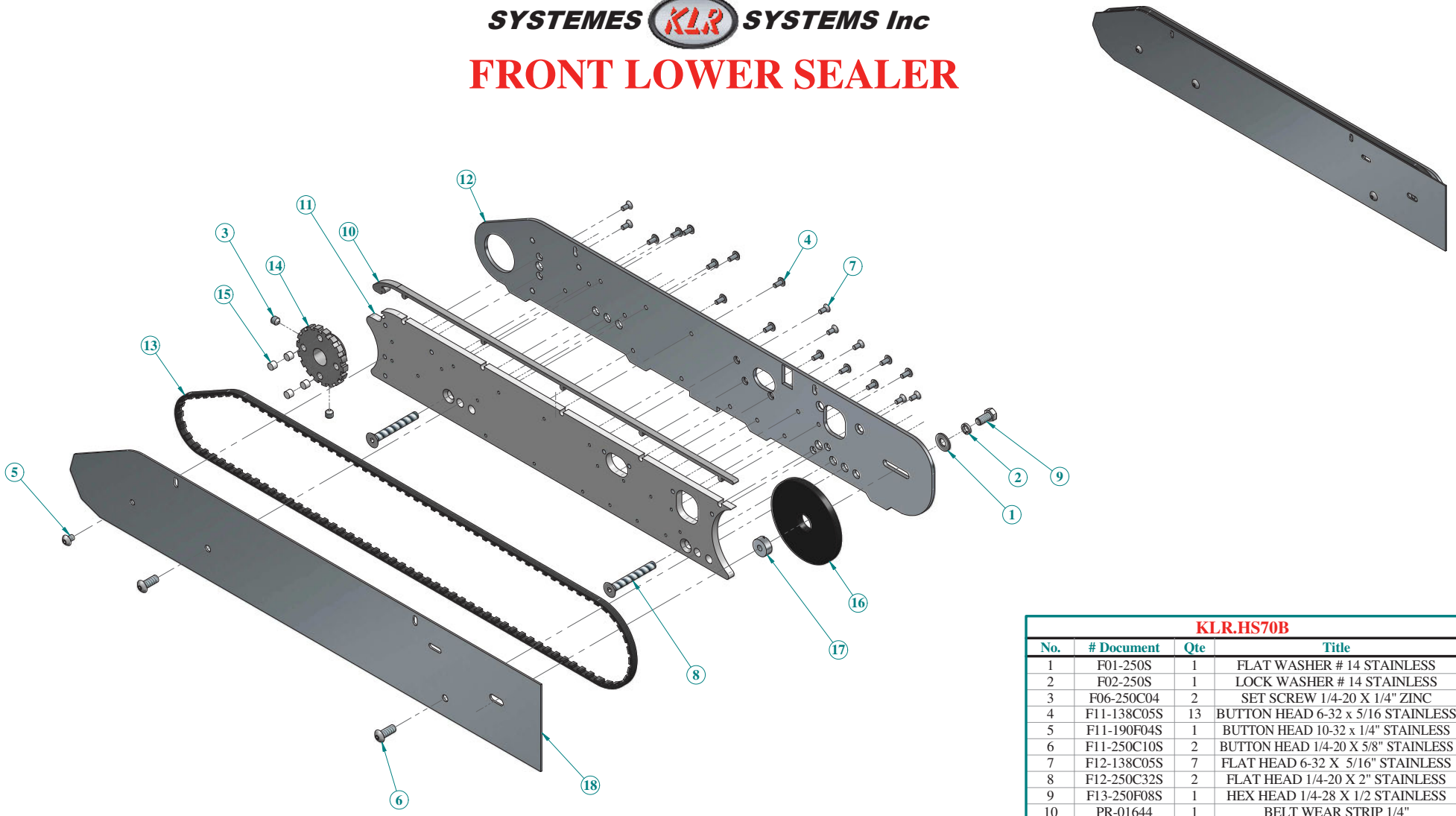

<b>KLR.HS70B</b>			
No.	# Document	Qty	Title
1	F01-250S	1	FLAT WASHER # 14 STAINLESS
2	F02-250S	1	LOCK WASHER # 14 STAINLESS
3	F06-250C04	2	SET SCREW 1/4-20 X 1/4" ZINC
4	F11-138C05S	13	BUTTON HEAD 6-32 x 5/16 STAINLESS
5	F11-190F04S	1	BUTTON HEAD 10-32 x 1/4" STAINLESS
6	F11-250C10S	2	BUTTON HEAD 1/4-20 X 5/8" STAINLESS
7	F12-138C05S	7	FLAT HEAD 6-32 X 5/16" STAINLESS
8	F12-250C32S	2	FLAT HEAD 1/4-20 X 2" STAINLESS
9	F13-250F08S	1	HEX HEAD 1/4-28 X 1/2 STAINLESS
10	PR-01644	1	BELT WEAR STRIP 1/4"
11	PR-01646	1	PRESSURE WHEEL
12	PR-01647	1	THIN BELT HOLDER PLATE
13	PR-01667	1	BELT
14	PR-01676	1	18TH TIMING PULLEY
15	PR-01676-A	4	PIN
16	PR-01677	1	WHEEL TENDER
17	PR-01680	1	SPACER
18	PR-01683-R	1	TOP SIDE FRAME

**SYSTEMES  SYSTEMS Inc**  
**BACK LOWER SEALER**

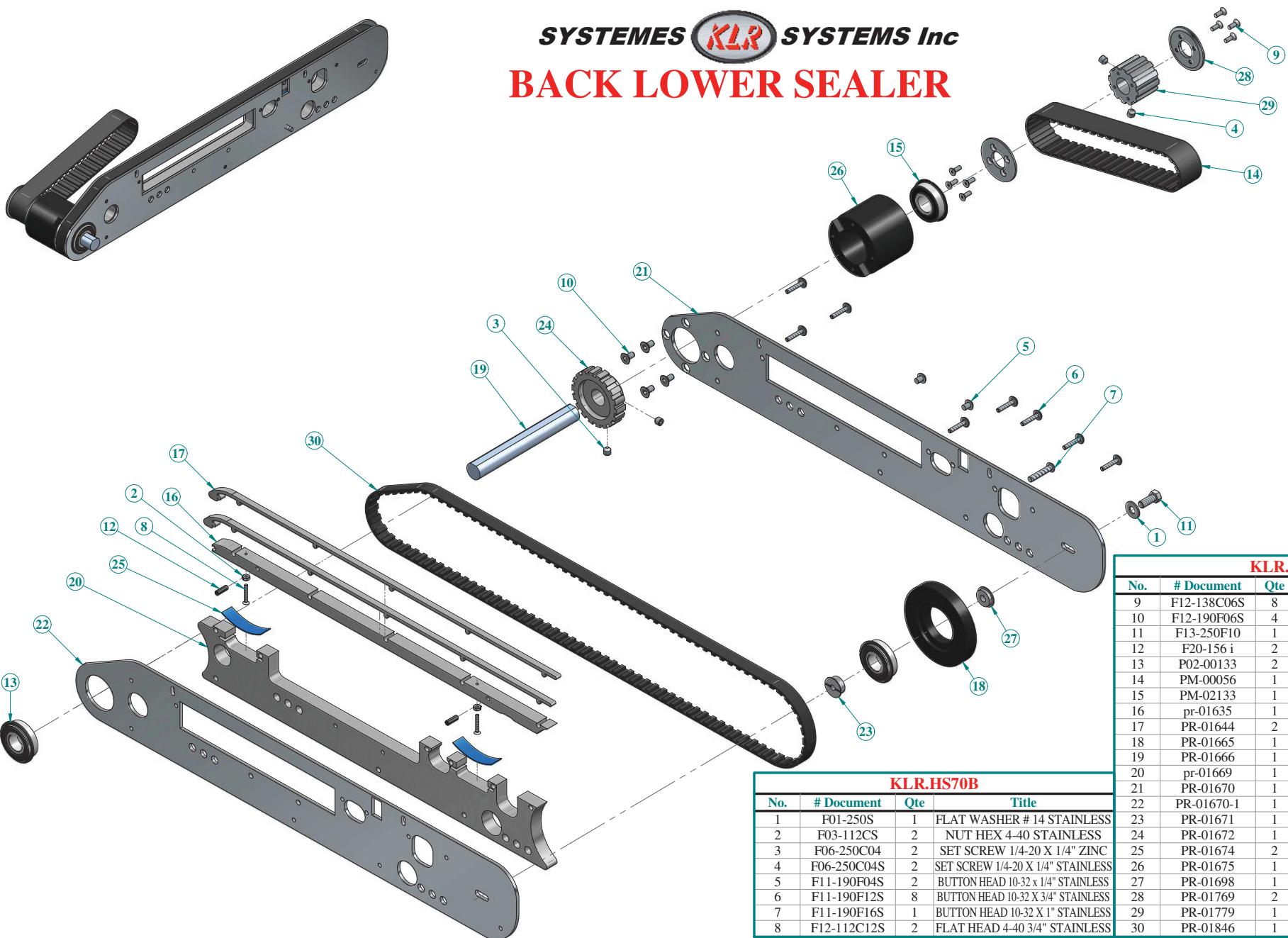

<b>KLR.HS70B</b>			
No.	# Document	Qty	Title
9	F12-138C06S	8	FLAT HEAD 6-32 X 3/8" STAINLESS
10	F12-190F06S	4	FLAT HEAD 10-32 X 3/8" STAINLESS
11	F13-250F10	1	HEX HEAD 1/4-28 X 5/8" ZINC
12	F20-156 1	2	SPRING PIN 5/32 X 1/2"
13	P02-00133	2	BEARING
14	PM-00056	1	BELT
15	PM-02133	1	BEARING
16	pr-01635	1	BELT PRESSURE BAR 1/2
17	PR-01644	2	BELT WEAR STRIP 1/4"
18	PR-01665	1	WHEEL IDLER
19	PR-01666	1	GEAR HOLDER
20	pr-01669	1	SPACER
21	PR-01670	1	WIDE BELT HOLDER PLATE
22	PR-01670-1	1	WIDE BELT HOLDER PLATE
23	PR-01671	1	NUT ROLLER
24	PR-01672	1	18TH TIMING PULLEY
25	PR-01674	2	SPRING STEEL
26	PR-01675	1	BEARING HOLDER
27	PR-01698	1	SPACER
28	PR-01769	2	SNAP FOR PR-01779
29	PR-01779	1	GEAR
30	PR-01846	1	BELT

<b>KLR.HS70B</b>			
No.	# Document	Qty	Title
1	F01-250S	1	FLAT WASHER # 14 STAINLESS
2	F03-112CS	2	NUT HEX 4-40 STAINLESS
3	F06-250C04	2	SET SCREW 1/4-20 X 1/4" ZINC
4	F06-250C04S	2	SET SCREW 1/4-20 X 1/4" STAINLESS
5	F11-190F04S	2	BUTTON HEAD 10-32 x 1/4" STAINLESS
6	F11-190F12S	8	BUTTON HEAD 10-32 X 3/4" STAINLESS
7	F11-190F16S	1	BUTTON HEAD 10-32 X 1" STAINLESS
8	F12-112C12S	2	FLAT HEAD 4-40 3/4" STAINLESS

**LOWER SEALER HEATER**

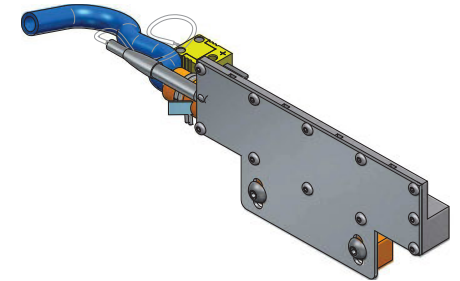
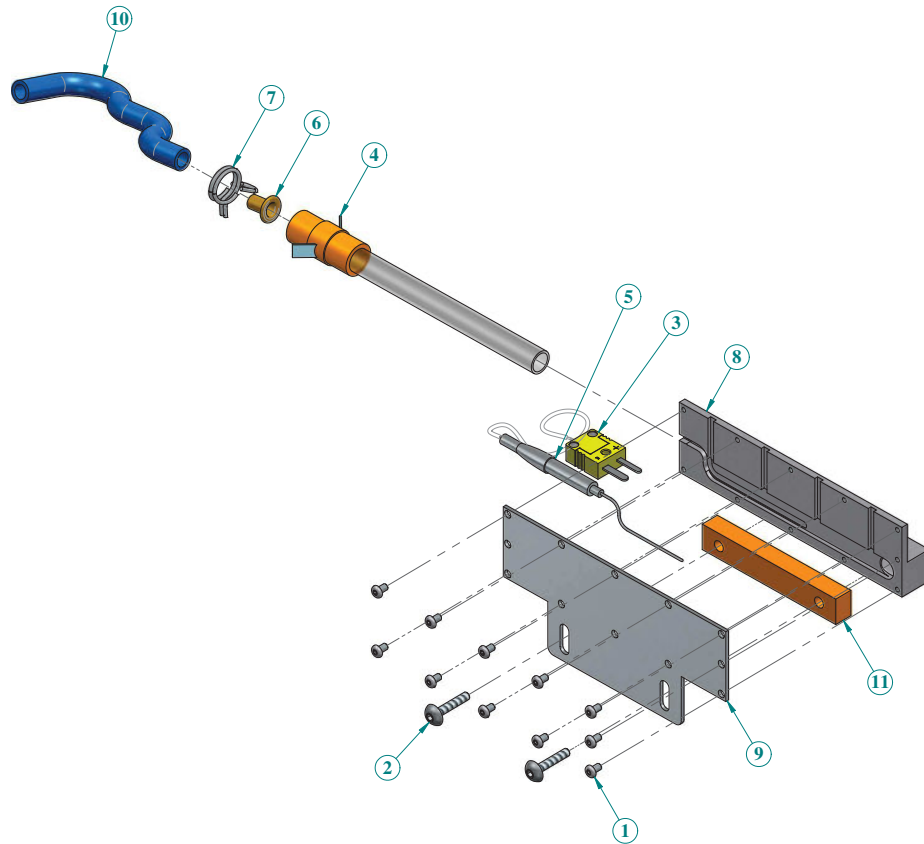

<b>KLR.HS70B</b>			
<b>No.</b>	<b># Document</b>	<b>Qty</b>	<b>Title</b>
1	F11-112C03S	11	BUTTON HEAD 4-40 X 3/16" STAINLESS
2	F11-190F12S	2	BUTTON HEAD 10-32 X 3/4" STAINLESS
3	PE-00368	1	THERMO COUPLE CONNECTOR MALE
4	PE-00370	1	ELEMENT HEATER
5	PE-00372	1	THERMOCOUPLE
6	PM-00326	1	EYELET
7	PM-01450	1	HOSE CLAMPS
8	PR-01614-R	1	BLOWER
9	PR-01639	1	SIDE COVER ELEMENT HEATER
10	PR-01699-5	1	HOSE
11	PR-01763	1	PHENOILIC SPACER



# Electrical plans

SINCE  
1977

---

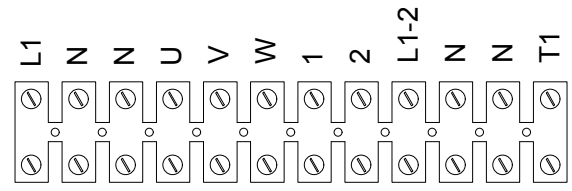
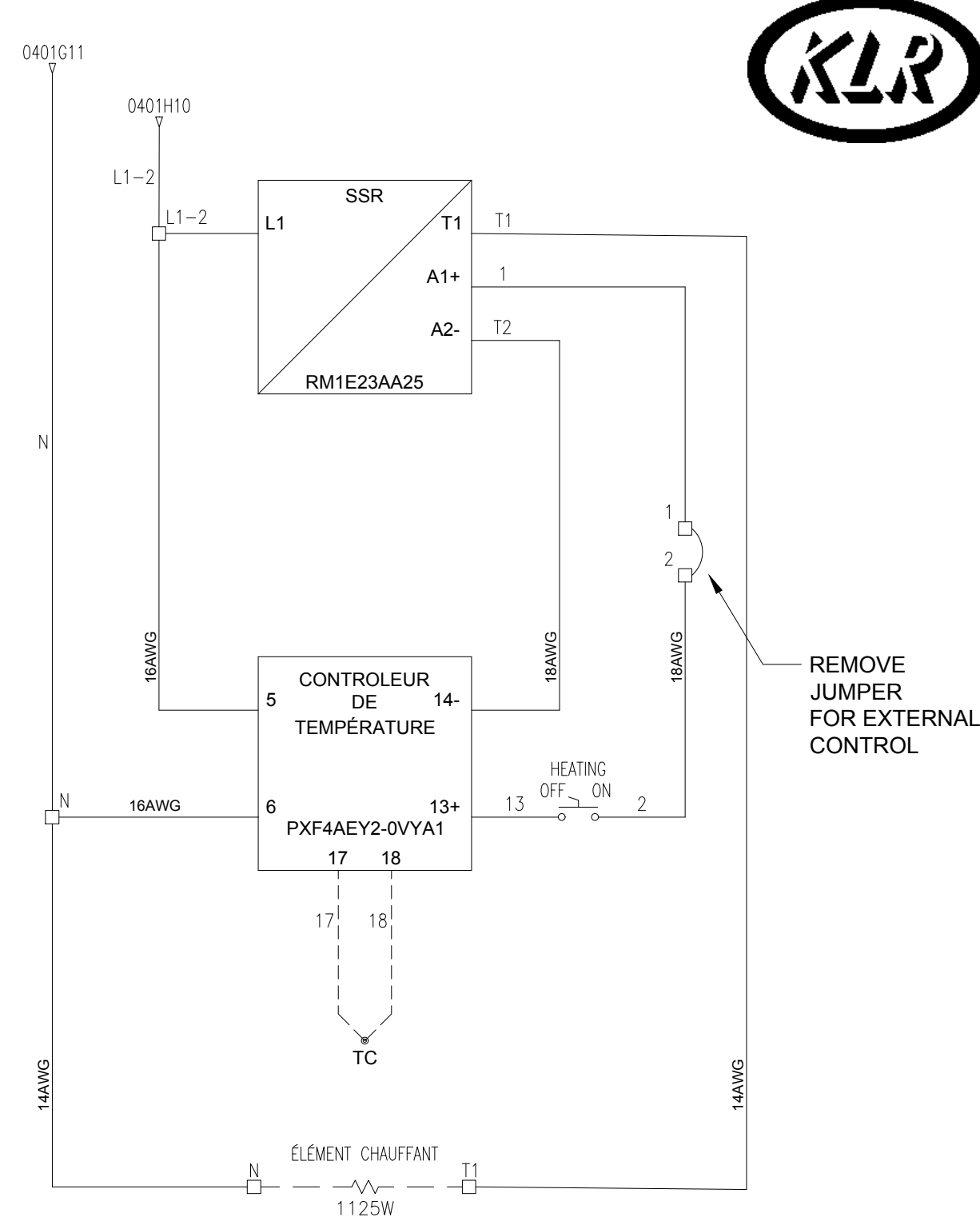
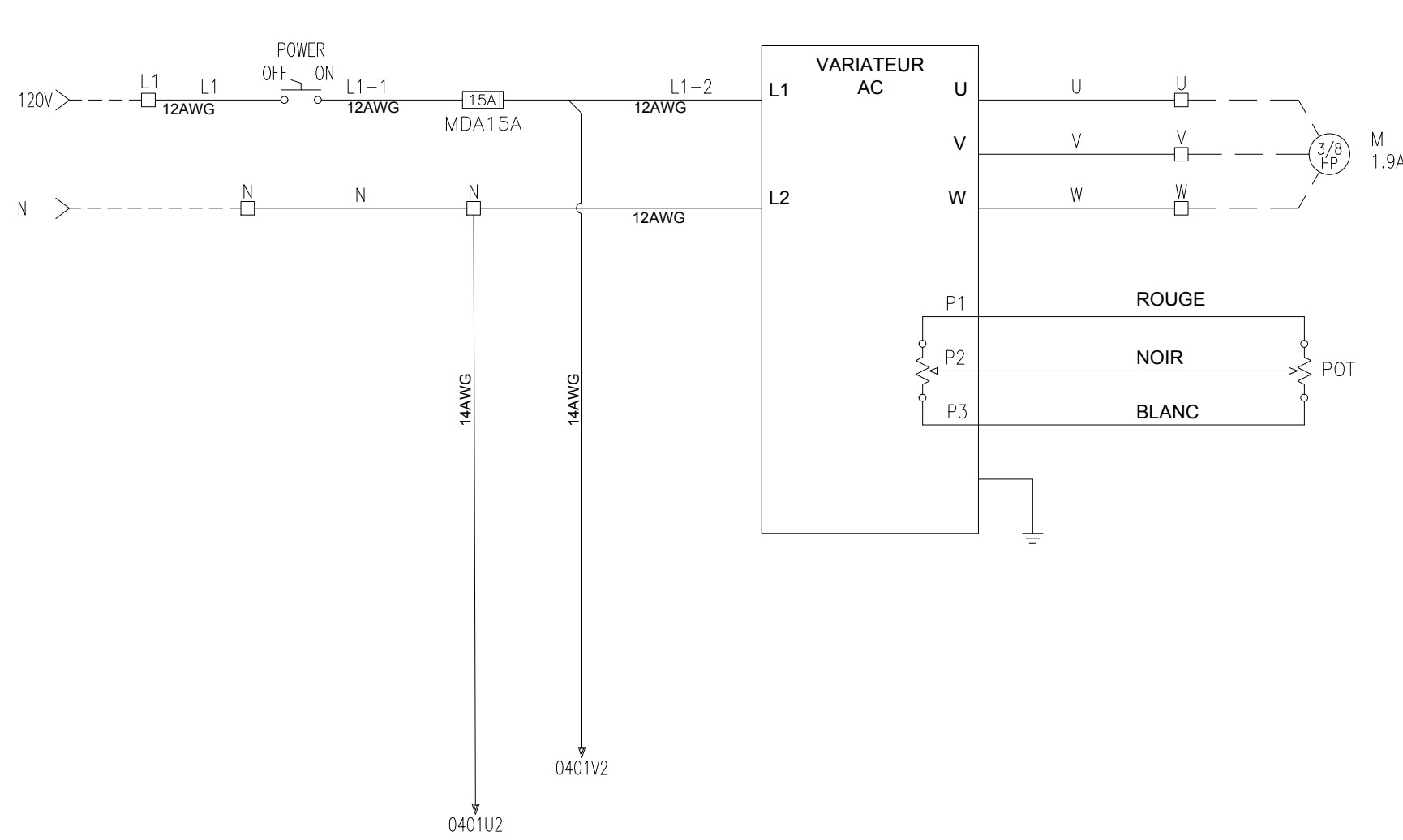

LEGEND	
□	SIMPLE TERMINAL BLOCK
○	DOUBLE TERMINAL BLOCK
△	TRIPLE TERMINAL BLOCK

REV	DATE	DESCRIPTION	DRAFTED BY:	PREPARED BY:	OIQ
2	2018-10-01	FINAL PLAN	J.L.	M.F.	5027316
1	2018-10-01	FOR CONSTRUCTION	J.L.	M.F.	5027316
0	2018-05-24	FOR CONSTRUCTION	J.L.	M.F.	5027316

REVISION HISTORY



4550, Avenue Beaudry  
 Saint-Hyacinthe, Quebec  
 J2S 8A5  
 Phone : (450) 774-1330  
 Toll-Free : 1 (800) 561-4709  
 FAX : (450) 774-1556  
 Email : admin@bectrol.com

CUSTOMER		SYSTEME KLR	
PROJECT TITLE		SEALER	
TITLE		DISTRIBUTION	
PROJECT	SECTION	PAGE	REVISION
F18-535	04	01	2





