

POUCH DESICCANT INSERTER

CVC 1103H



The CVC 1103H Pouch Desiccant Inserter is a compact highly cost-effective means to insert desiccants or oxygen absorbers into a variety of bottles and containers. The system cuts packets from a roll and inserts them into containers at speeds of up to 230 bottles per minute. The CVC 1103H is Siemens PLC controlled with servo motor. Options include 3-color stack light and feed screw for higher speed applications.

STANDARD FEATURES

- Servo Motor & Siemens PLC Controlled
- Display touchscreen instruction for machine operation is available in multiple languages
- Capability of recipe storage
- Infeed feed screw system for high speed applications
- Storage and printing of Production Report and Alarm Report
- Safety guards with automatic machine stop when opened
- Special heavy duty blades for longer durability
- Flexible adjustments can meet different product bottle heights
- Type 304 stainless steel bin, frame, enclosure panels
- CE or UL/ CSA standard PC safety guard
- ISO 9001:2015 certified

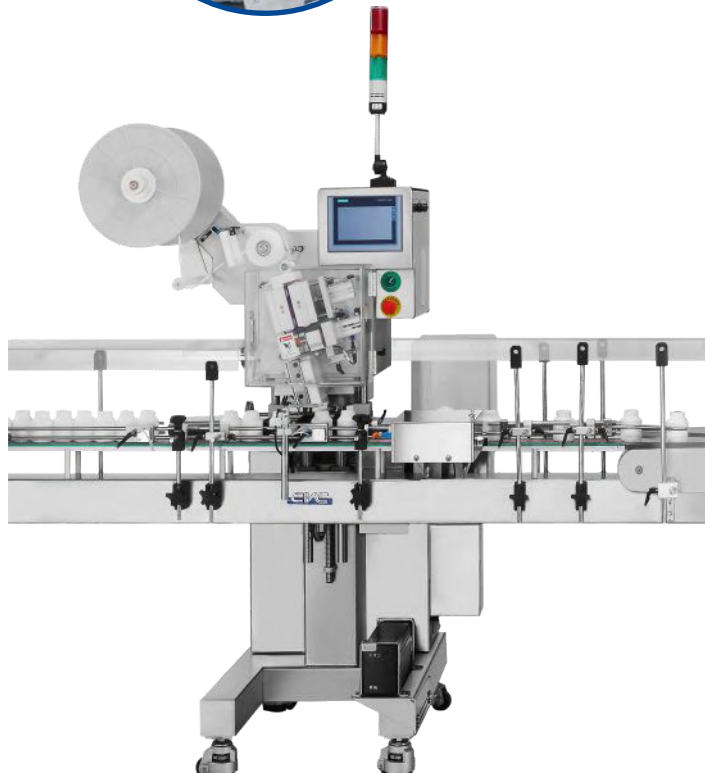

CVC 1103H Technical Specifications

Type	U4
Productivity	Up to 230 BPM (based on 100ml round bottle and 0.5g, L: 35-38 mm pouch, subject to trial confirmation)
Applicable Size	Pouch Type: R-Type: Paper F-Type: Film Pouch Size Range: Thickness: 3- 10 mm (1/8" to 3/8") Length: 33- 75 mm (1 1/4" to 3") Width: 17- 30 mm (5/8" to 1 1/8") Bottle Size Range: Dia.: Ø30- 124 mm (1 1/4" to 4 3/4") Height: 50- 220 mm (2" to 8 1/2") Bottle opening: Ø20- 100 mm (3/4" to 3 3/4")
Power Source	220 V, 50/60 Hz, 1 PH
Power Consumption	900 VA (4 A)
Air Pressure	6 bar (87 psi)
Air Consumption	115 NL/min (4 CFM)
Machine Dimensions (L x W x H)	910 x 985 x 2,270 mm (3'-0" x 3'-3" x 6'-11")
Machine Weight	190 kg (418 lbs)
Noise Level	≤ 70 dB

Technical data contained in this material are not binding and may be subject to change without prior notice.

TECHNICAL SPECIFICATIONS

AVAILABLE OPTIONS

- Bottle Feed Screw (Container Format Parts)
- Bottle Reject System
- Bottle Reject Verification Check
- Pouch Desiccant Chute (Pouch Format Parts)
- Dust Cover of Desiccant Roll
- 3-Color Stack Light
- 21 CFR Part 11 Compliance
- OPC UA for Data Collection



• Pouch Desiccant Cutting and Dispensing Mechanism

MACHINE LAYOUTS

Top View

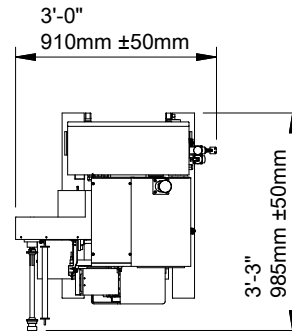

Front View

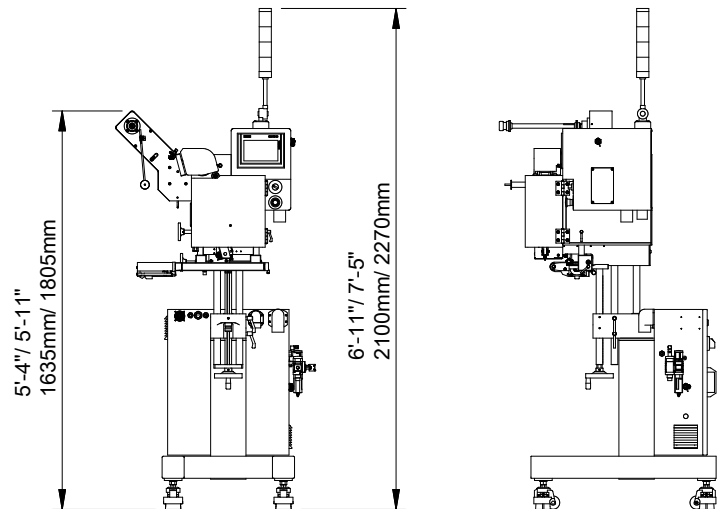

Technical data contained in this material are not binding and may be subject to change without prior notice.



Contact Us

USA

10861 Business Drive, Fontana, CA 92337
Phone: +1 (909) 355-0311
www.cvcusa.com; www.cvctechnologies.com
sales@cvcusa.com

Taiwan-Asia Pacific Headquarters

Phone: +886 (4) 2496-3666
sales@cvctechnologies.com

India

Phone: +91 (22) 2562-1242, +91 (22) 2562-1243
sales@cvctechnologies.com

China

Phone: +86 (512) 8363-6368
sales@cvctechnologies.com